

# DELTA<sup>®</sup>

## 13 inch Portable Planer

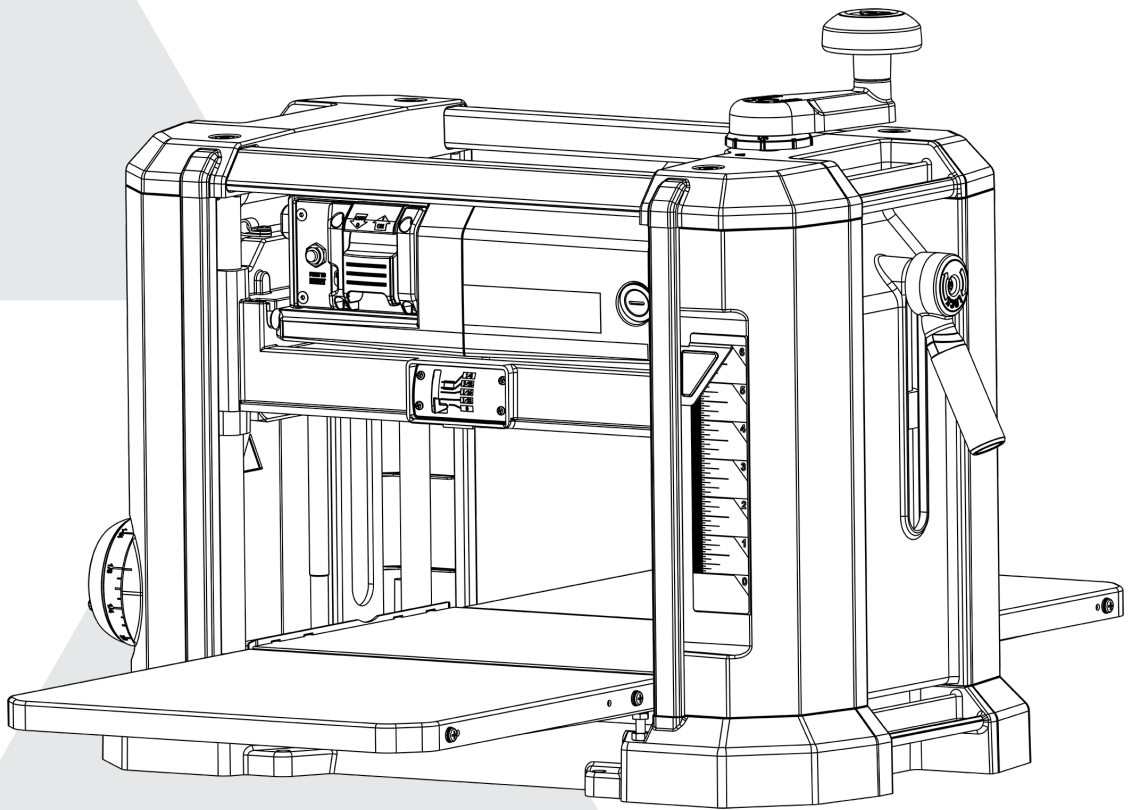

[www.DeltaMachinery.com](http://www.DeltaMachinery.com)

Instruction Manual

### 22-590X

**⚠ WARNING:** To reduce the risk of serious injury, thoroughly read and comply with all warnings and instructions in this manual and on product  
**KEEP THIS MANUAL NEAR YOUR PRODUCT FOR EASY REFERENCE AND TO INSTRUCT OTHERS**



# TABLE OF CONTENTS

<b>FEATURES</b> .....	<b>2</b>	ADJUSTING THE HEAD ASSEMBLY.....	12
<b>IMPORTANT SAFETY INSTRUCTIONS</b> .....	<b>4</b>	USING THE MATERIAL REMOVAL GAUGE.....	12
<b>SAFETY GUIDELINES - DEFINITIONS</b> .....	<b>4</b>	RECOMMENDED DEPTH OF CUT .....	13
<b>GENERAL SAFETY RULES</b> .....	<b>5</b>	USING THE DEPTH STOP.....	13
<b>PLANER SAFETY RULES</b> .....	<b>6</b>	USING THE ADJUSTABLE INDEXING RING.....	14
<b>PROPOSITION 65 WARNING</b> .....	<b>6</b>	MINIMUM/MAXIMUM WIDTH/HEIGHT/DEPTH.....	14
<b>POWER CONNECTIONS</b> .....	<b>7</b>	PROPER PLANING TECHNIQUES .....	14
POWER SOURCE .....	7	<b>MAINTENANCE/ADJUSTMENTS</b> .....	<b>15</b>
GROUNDING INSTRUCTIONS .....	7	CHECKING, ADJUSTING, CLEANING AND REPLACING	
ELECTRICAL CONNECTION.....	7	KNIVES .....	15
POLARIZED PLUGS .....	7	ADJUSTING THE IN-FEED AND OUT-FEED TABLES .....	17
EXTENSION CORDS .....	7	CALIBRATING THE INDICATOR ARROW.....	18
<b>UNPACKING</b> .....	<b>8</b>	WEAR TABLE AND IN-FEED/ OUT-FEED TABLE	
UNPACKING AND CLEANING.....	8	MAINTENANCE .....	18
PACKAGE CONTENTS .....	8	CIRCUIT BREAKER RESET BUTTON .....	18
<b>ASSEMBLY</b> .....	<b>9</b>	BRUSH CHANGE.....	18
ATTACHING THE CUTTERHEAD LOCK HANDLE.....	9	REPLACING THE DRIVE BELT .....	18
ATTACHING THE CUTTERHEAD HEIGHT ADJUSTING		KEEP MACHINE CLEAN .....	18
HANDLE .....	9	LUBRICATION.....	18
PREPARING FOR DUST MANAGEMENT .....	10	<b>TROUBLESHOOTING</b> .....	<b>19</b>
FASTENING THE PLANER TO A SUPPORTING SURFACE ...	11	FAILURE TO START .....	19
<b>OPERATION</b> .....	<b>11</b>	<b>ACCESSORIES</b> .....	<b>19</b>
STARTING AND STOPPING THE PLANER.....	11	<b>PARTS, SERVICE OR WARRANTY ASSISTANCE</b> .....	<b>20</b>
USING THE CUTTERHEAD LOCK .....	12		

## FEATURES

The DELTA® Model 22-590X is a 13 inch (330mm) Portable Planer with a cutting capacity of 1/8 inch (3.2mm). This Planer can be used on boards up to 13 inch wide (330mm) and 6 inch thick (152mm). This machine has a powerful 15 amp 120 volt motor with a three-knife cutterhead.

**NOTICE:** The cover illustration shows the current production model configuration. All other illustrations contained in the manual are representative **ONLY** and may not depict the actual labeling or accessories included. These are intended to illustrate technique **ONLY**.

### MOTOR SPECIFICATIONS

Your machine is wired for 120 volt, 60 Hz alternating current. Before connecting the machine to the power source, make sure the switch is in the "OFF" position.

**NOTE:** You can make a 1/8 inch (3.2mm) depth-of-cut in soft woods up to 6 inch (152mm) wide and in hard woods up to 4 inch (102mm) wide. For more information see "Recommended Depth of Cut section" on page 13.

### SPECIFICATIONS

Supply Voltage:	120 V AC~
Current:	15 A
Frequency:	60 Hz
No Load RPM:	10,000/min

# FEATURES

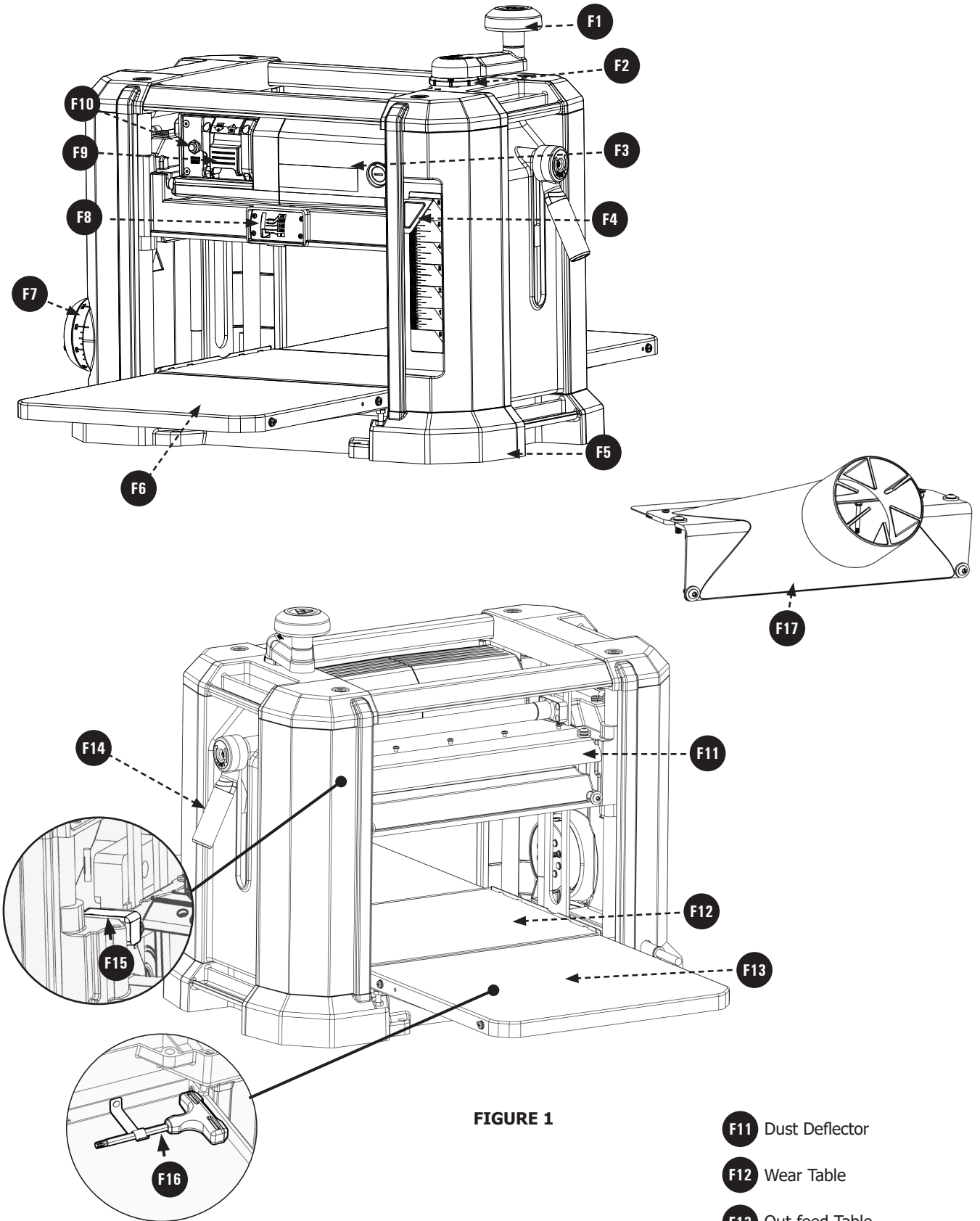

**FIGURE 1**

- F1** Cutterhead Height Adjusting Handle
- F2** Micro Adjustment
- F3** Main Housing
- F4** Indicator Arrow
- F5** Base
- F6** In-feed Table
- F7** Depth Stop Knob / Lock
- F8** Material Removal Gauge
- F9** On/Off Switch
- F10** Reset Button
- F11** Dust Deflector
- F12** Wear Table
- F13** Out-feed Table
- F14** Cutterhead Lock Handle
- F15** Cutterhead Lock Release
- F16** Wrench Storage (Under Table)
- F17** Dust Collection Attachment

# IMPORTANT SAFETY INSTRUCTIONS

**⚠ WARNING:** READ AND UNDERSTAND ALL WARNINGS AND OPERATING INSTRUCTIONS BEFORE USING ANY TOOL OR EQUIPMENT. ALWAYS FOLLOW BASIC SAFETY PRECAUTIONS TO REDUCE THE RISK OF PERSONAL INJURY. Improper operation, maintenance, or modification of tools or equipment could result in serious injury and property damage. There are certain applications for which tools and equipment are designed. **DO NOT** modify and/or use this product for **ANY** application other than that for which it was designed.



If you have any questions or concerns relative to the use of your tool or the contents of this manual, stop using the tool and contact DELTA® Customer Service (toll free) 1-800-223-7278.

- Power Tool Institute, 1300 Sumner Avenue, Cleveland, OH 44115-2851 or online at [www.powertoolinstitute.com](http://www.powertoolinstitute.com).
- National Safety Council, 1121 Spring Lake Drive, Itasca, IL 60143-3201.
- American National Standards Institute, 25 West 43rd Street, 4 floor, New York, NY 10036 [www.ansi.org](http://www.ansi.org) - ANSI 01.1 Safety Requirements for Woodworking Machines.
- U.S. Department of Labor regulations [www.osha.gov](http://www.osha.gov).

## SAFETY GUIDELINES - DEFINITIONS

It is important for you to read and understand this manual. The information it contains relates to protecting YOUR SAFETY and PREVENTING PROBLEMS. The symbols below are used to help you recognize this information.

**⚠ DANGER:** Indicates an imminently hazardous situation which, if not avoided, will result in death or serious injury.

**⚠ WARNING:** Indicates a potentially hazardous situation which, if not avoided, could result in death or serious injury.

**⚠ CAUTION** Indicates a potentially hazardous situation which, if not avoided, may result in minor or moderate injury.

**CAUTION:** Indicates a practice not related to personal injury which, if not avoided, may result in property damage.

Some of the following symbols may be used on the tool. Please study them and learn their meaning. Proper interpretation on these symbols will allow you to operate the tool better and safer.

SYMBOL	NAME	DESIGNATION/EXPLANATION
	Safety Alert	Indicates a potential personal injury hazard.
	Read Operator's Manual	To reduce the risk of injury, user must read and understand operator's manual before using this product.
	Eye Protection	Always wear eye protection with side shields marked to comply with ANSI Z87.1.
	No Hands Symbol	Failure to keep your hands away from the blade will result in serious personal injury.
	Wet Conditions Alert	Do not expose to rain or use in damp locations.
	Pinch Warning	Always watch for movement paying extra attention to potential areas where pinching could occur.
V	Volts	Voltage
A	Amperes	Current
Hz	Hertz	Frequency (cycles per second)
min	Minutes	Time
~/AC	Alternating Current	Type of current
n <sub>0</sub>	No Load Speed	Rotational speed, at no load
.../min	Per Minute	Revolutions, strokes, surface speed, orbits, etc., per minute
Lbs	Pounds	Unit of weight
Kg	Kilograms	Unit of weight
RPM	Revolutions Per Minute	Speed of rotation of machine
PH:1	Phase 1	This is a 1 phase motor

# GENERAL SAFETY RULES

**⚠ WARNING:** Failure to follow these rules may result in serious personal injury.

- 1. For your own safety, read the instruction manual before operating the machine.** Learning the machine's application, limitations, and specific hazards will greatly minimize the possibility of accidents and injury.
- 2. Wear eye and hearing protection and ALWAYS use safety glasses.** Everyday eyeglasses are not safety glasses. Use certified safety equipment. Eye protection equipment should comply with ANSI Z87.1 standards. Hearing equipment should comply with ANSI S3.19 standards.
- 3. Wear proper apparel. Do not** wear loose clothing, gloves, neckties, rings, bracelets, or other jewelry which may get caught in moving parts. Nonslip protective footwear is recommended. Wear protective hair covering to contain long hair.
- 4. Do not use the machine in a dangerous environment.** The use of power tools in damp or wet locations or in rain can cause shock or electrocution. **KEEP** your work area well-lit to prevent tripping or placing arms, hands, and fingers in danger.
- 5. Do not operate electric tools near flammable liquids or in gaseous or explosive atmospheres.** Motors and switches in these tools may spark and ignite fumes.
- 6. Maintain all tools and machines in peak condition. KEEP** tools sharp and clean for best and safest performance. Follow instructions for lubricating and changing accessories. Poorly maintained tools and machines can further damage the tool or machine and/or cause injury.
- 7. Check for damaged parts.** Before using the machine, check for any damaged parts. Check for alignment of moving parts, binding of moving parts, breakage of parts, and any other conditions that may affect its operation. A guard or any other part that is damaged should be properly repaired or replaced with DELTA® or factory authorized replacement parts. Damaged parts can cause further damage to the machine and/or injury.
- 8. KEEP the work area clean.** Cluttered areas and benches invite accidents.
- 9. KEEP children and visitors away.** Your shop is a potentially dangerous environment. Children and visitors can be injured.
- 10. Reduce the risk of unintentional starting.** Make sure that the switch is in the "OFF" position before plugging in the power cord. In the event of a power failure, move the switch to the "OFF" position. An accidental start-up can cause injury. Do not touch the plug's metal prongs when unplugging or plugging in the cord.
- 11. Use the guards.** Check to see that all safety devices are in place, secured, and working correctly to prevent injury.
- 12. Remove adjusting keys and wrenches before starting the machine.** Tools, scrap pieces, and other debris can be thrown at high speed, causing injury.
- 13. Use the right machine.** Do not force a machine or an attachment to do a job for which it was not designed. Damage to the machine and/or injury may result.
- 14. Use recommended accessories.** The use of accessories and attachments not recommended by DELTA® may cause damage to the machine or injury to the user.
- 15. Use the proper extension cord.** Make sure your extension cord is in good condition. When using an extension cord, be sure to use one heavy enough to carry the current your product will draw. An undersized cord will cause a drop in line voltage, resulting in loss of power and overheating. See the Extension Cord Chart for the correct size depending on the cord length and nameplate ampere rating. If in doubt, use the next heavier gauge. The smaller the gauge number, the heavier the cord.
- 16. Secure the workpiece.** Use clamps or a vise to hold the workpiece when practical. Loss of control of a workpiece can cause injury.
- 17. Feed the workpiece against the direction of the rotation of the blade, cutter, or abrasive surface.** Feeding it from the other direction will cause the workpiece to be thrown out at high speed.
- 18. Do not force the workpiece on the machine.** Damage to the machine and/or injury may result.
- 19. Do not overreach.** Loss of balance can make you fall into a working machine, causing injury.
- 20. NEVER stand on the machine.** Injury could occur if the tool tips, or if you accidentally contact the cutting tool.
- 21. NEVER leave the machine running unattended.** Turn the power off. Don't leave the machine until it comes to a complete stop. A child or visitor could be injured.
- 22. Turn the machine "OFF", and disconnect the machine from the power source before installing or removing accessories, changing cutters, adjusting or changing set-ups.** When making repairs, be sure to lock the start switch in the "OFF" position. An accidental start-up can cause injury.
- 23. Make your workshop childproof with padlocks, master switches, or by removing starter keys.** The accidental start-up of a machine by a child or visitor could cause injury.
- 24. Stay alert, watch what you are doing, and use common sense. Do not** use the machine when you are tired or under the influence of drugs, alcohol, or medication. A moment of inattention while operating power tools may result in injury.
- 25. ⚠ WARNING:** Use of this tool can generate and disperse dust or other airborne particles, including wood dust, crystalline silica dust and asbestos dust. Direct particles away from face and body. **ALWAYS** operate tool in well ventilated area and provide for proper dust removal. Use dust collection system wherever possible. Exposure to the dust may cause serious and permanent respiratory or other injury, including silicosis (a serious lung disease), cancer, and death. Avoid breathing the dust, and avoid prolonged contact with dust. Allowing dust to get into your mouth or eyes, or lay on your skin may promote absorption of harmful material. **ALWAYS** use properly fitting NIOSH/OSHA approved respiratory protection appropriate for the dust exposure, and wash exposed areas with soap and water.

# PLANER SAFETY RULES

## **⚠ WARNING:** FAILURE TO FOLLOW THESE RULES MAY RESULT IN SERIOUS PERSONAL INJURY.

- 1. Do not operate this machine** until it is completely assembled and installed according to the instructions. A machine incorrectly assembled can cause serious injury.
- 2. Obtain advice** from your supervisor, instructor, or another qualified person if you are not thoroughly familiar with the operation of this machine. Knowledge is safety.
- 3. Follow all wiring codes** and recommended electrical connections to prevent shock or electrocution.
- 4. Keep knives sharp** and free from rust and pitch. Dull or rusted knives work harder and can cause kickback.
- 5. Never turn the machine "ON"** before clearing the table of all objects (tools, scraps of wood, etc.). Flying debris can cause serious injury.
- 6. Never turn the machine "ON"** with the work-piece contacting the cutterhead. Kickback can occur.
- 7. Secure the machine to a supporting surface** to prevent the machine from sliding, walking or tipping over.
- 8. Properly secure the knives in the cutter-head** before turning the power "ON". Loose blades may be thrown out at high speeds causing serious injury.
- 9. Do not place the power cord** under the cutterhead when moving or storing.
- 10. Avoid awkward operations and hand positions.** A sudden slip could cause a hand to move into the knives.
- 11. Keep arms, hands, and fingers** away from the cutterhead, the chip exhaust opening, and the feed rollers to prevent severe cuts.
- 12. Never reach into the cutterhead area** while the machine is running. Your hands can be drawn into the knives.
- 13. Do not stand in line of the workpiece.** Kickback can cause injury.
- 14. Allow the cutterhead to reach full speed** before feeding a workpiece.
- 15. When planning stock,** place the concave (cup down) side of the stock on the table and cut with the grain to prevent kickback.
- 16. Do not feed workpiece** that is warped, contains knots, or is embedded with foreign objects (nails, staples, etc.). Kickback can occur.
- 17. Do not feed a short, thin, or narrow workpiece into the machine.** Your hands can be drawn into the knives and/or the workpiece can be thrown at high speeds. See the "OPERATION" section of this instruction manual for details.
- 18. Do not feed workpiece** into the out-feed end of the machine. The workpiece will be thrown out of the opposite side at high speeds.
- 19. Remove shavings only** with the power "OFF" to prevent serious injury.
- 20. Use for wood only. Do not** plane man-made materials.
- 21. Properly support long or wide workpieces.** Loss of control of the workpiece can cause serious injury.
- 22. Never perform layout, assembly** or set-up work on the table/work area when the machine is running. Serious injury will result.
- 23. Turn the machine "OFF", disconnect it from the power source,** and clean the table/work area before leaving the machine. Lock the switch in the "OFF" position to prevent unauthorized use.
- 24. Additional information** regarding the safe and proper operation of power tools (i.e. a safety video) is available from the Power Tool Institute, 1300 Sumner Avenue, Cleveland, OH 44115-2851 ([www.powertoolinstitute.com](http://www.powertoolinstitute.com)). Information is also available from the National Safety Council, 1121 Spring Lake Drive, Itasca, IL 60143-3201. Please refer to the American National Standards Institute ANSI 01.1 Safety Requirements for Woodworking Machines and the U.S. Department of Labor Regulations.

## PROPOSITION 65 WARNING:

**⚠ WARNING:** Dust created by power sanding, sawing, grinding, drilling, and other construction activities may contain chemicals known to the state of California to cause cancer, birth defects or other reproductive harm. Some examples are:

- Lead from lead-based paints
- Crystalline silica from bricks and cement and other masonry products
- Asbestos dust
- Arsenic and chromium from chemically-treated lumber

Your risk from these exposures varies depending on how often you do this type of work. To reduce your exposure to these chemicals: work in a well-ventilated area and work with approved safety equipment, such as dust masks that are specifically designed to filter out microscopic particles.

Avoid prolonged contact with dust from power sanding, sawing, grinding, drilling, and other construction activities.

Wear protective clothing and wash exposed areas with soap and water.

## SAVE THESE INSTRUCTIONS

Refer to them often and use them to instruct others. • If tool is loaned to someone, also loan them these instructions.

# POWER CONNECTIONS

## POWER SOURCE

This planer is equipped with a 15-amp motor for use with a 120-volt, 60-HZ alternating current. See instructions below regarding proper connections for your saw as wired.

For voltage, the wiring in a shop is as important as the motor's rating. A line intended **ONLY** for lights may not be able to properly carry the current needed for a power tool motor; wire that is heavy enough for a short distance may be too light for a greater distance; and a line that can support one power tool may not be able to support two or three. A separate electrical circuit should be used for your machines. This circuit should not be less than #12 wire and recommended to be protected with a 20-amp circuit breaker or a 20-amp time lag fuse. If an extension cord is used, use **ONLY** 3-wire extension cords which have 3-prong grounding-type plugs and matching receptacle which will accept the machine's plug. Before connecting the machine to the power line, make sure the switch(s) is in the "OFF" position and be sure that the electric current is of the same characteristics as indicated on the machine. A substantial voltage drop will cause a loss of power and overheat the motor. It may also damage the machine.

**⚠ DANGER:** DO NOT EXPOSE THE MACHINE TO RAIN OR OPERATE THE MACHINE IN DAMP LOCATIONS.

Your machine is wired for 120 volts, 60 HZ alternating current. Before connecting the machine to the power source, make sure the switch is in the "OFF" position.

---

## GROUNDING INSTRUCTIONS

**⚠ DANGER:** This machine must be grounded while in use to protect the operator from electric shock.

### 1. All grounded, cord-connected machines:

In the event of a malfunction or breakdown, grounding provides a path of least resistance for electric current to reduce the risk of electric shock. This machine is equipped with an electric cord having an equipment-grounding conductor and a grounding plug. The plug must be plugged into a matching outlet that is properly installed and grounded in accordance with all local codes and ordinances.

**DO NOT** modify the plug provided - if it will not fit the outlet, have the proper outlet installed by a qualified electrician.

Improper connection of the equipment-grounding conductor can result in risk of electric shock. The conductor with insulation having an outer surface that is green with or without yellow stripes is the equipment-grounding conductor. If repair or replacement of the electric cord or plug is necessary, **DO NOT** connect the equipment-grounding conductor to a live terminal.

Check with a qualified electrician or service personnel if the grounding instructions are not completely understood, or if in doubt as to whether the machine is properly grounded.

Use **ONLY** 3-wire extension cords that have 3-prong grounding type plugs and matching 3-conductor receptacles that accept the machine's plug.

Repair or replace damaged or worn cord immediately.

**⚠ DANGER:** In all cases, make certain that the receptacle in question is properly grounded. If you are not sure, have a qualified electrician check the receptacle.

---

## ELECTRICAL CONNECTION

This tool has a precision-built electric motor. It should be connected to a POWER SUPPLY THAT IS 120 VOLTS, 60 HZ, AC **ONLY** (NORMAL HOUSEHOLD CURRENT in the U.S. and Canada). **DO NOT** operate this tool on direct current (DC). A substantial voltage drop will cause a loss of power and the motor will overheat. If the tool does not operate when plugged into an outlet, double-check the power supply.

---

## POLARIZED PLUGS

To reduce the risk of electric shock, this equipment has a polarized plug (one blade is wider than the other). This plug will fit in a polarized outlet **ONLY** one way. If the plug does not fully fit in the outlet reverse the plug. If it still does not fit, contact a qualified electrician to install the proper outlet. **DO NOT** change the plug in any way.

# POWER CONNECTIONS

## EXTENSION CORDS

When using a power tool at a considerable distance from a power source, be sure to use a 3-prong extension cord that has the capacity to handle the current the tool will draw. An undersized cord will cause a drop in line voltage, resulting in overheating and loss of power. Use the chart to determine the minimum wire size required in an extension cord. **ONLY** round jacketed cords listed by Underwriter's Laboratories (UL) should be used.

**NOTE:** Before using any extension cord, inspect it for loose or exposed wires and cut or worn insulation.

**⚠ WARNING:** **KEEP** the extension cord clear of the work area. Position the cord so that it will not get caught on lumber, tools or other obstructions while you are working with a power tool. Failure to do so can result in serious personal injury. Check extension cords before each use. If damaged replace immediately. **NEVER** use tool with a damaged cord, since touching the damaged area could cause electrical shock resulting in serious injury.

** Ampere rating (on total data label)	
<b>12A-16A</b>	
Cord Length	Wire Size
25'	14 AWG
50'	12 AWG
** Used on 12 gauge - 20 amp circuit	
<b>NOTE:</b> AWG = American Wire Gauge	

# UNPACKING

## UNPACKING AND CLEANING

**⚠ CAUTION** This machine weighs about 75 pounds. Use a helper to lift or move it.

Carefully unpack the machine and all loose items from the shipping container. Figure 2 illustrates the planer and all loose items supplied with your machine. Refer to the section of this manual titled "Replacing Knives" to remove the dust deflector. Remove any rust-preventative oil from unpainted surfaces using a soft cloth moistened with mineral spirits, paint thinner or denatured alcohol.

**⚠ WARNING:** **DO NOT** use highly volatile solvents such as gasoline, naphtha, acetone or lacquer thinner for cleaning your machine.

After cleaning, cover the unpainted surfaces with a good quality household floor paste wax.

**⚠ WARNING:** Take care when you clean the cutterhead. The knives in the cutterhead are very sharp. After cleaning the cutterhead, replace the dust deflector.

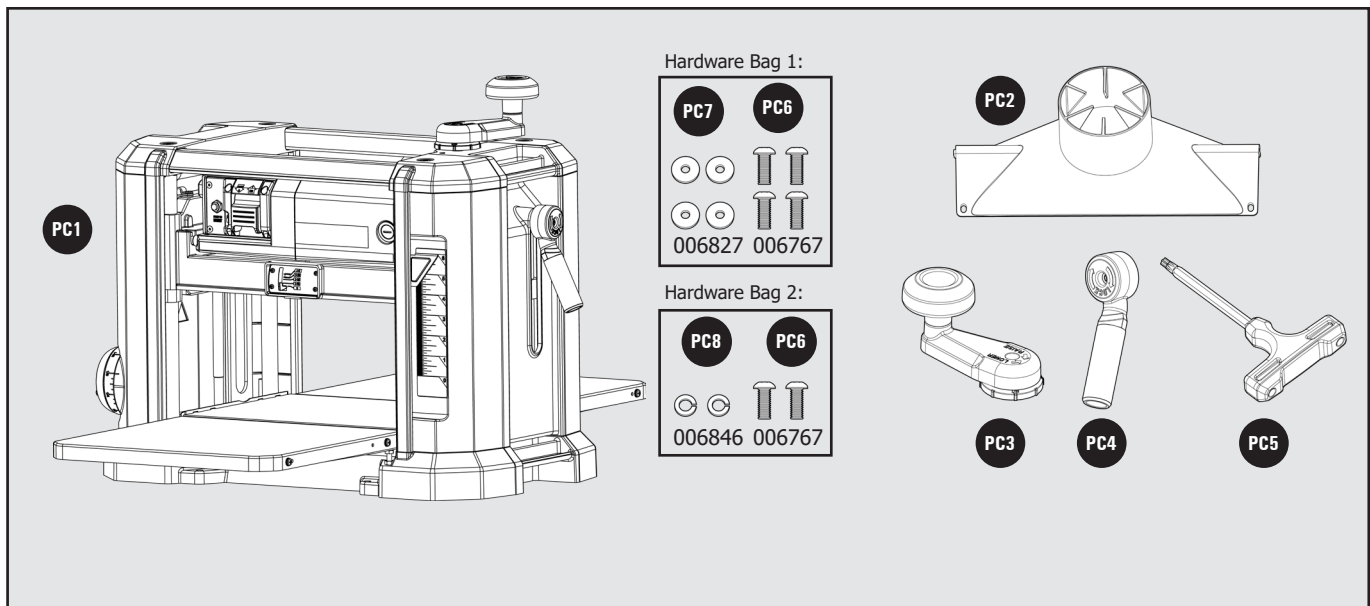

FIGURE 2

## PACKAGE CONTENTS

- **PC1** 22-590X Portable Planer
- **PC5** T-Handle T30 Torx Wrench
- **PC2** Dust Collection Attachment
- **PC6** M6 x 20mm Torx Head Screw (6)
- **PC3** Cutterhead Height Adjusting Handle
- **PC7** 6.5mm x 16mm x 2mm Flat Washer (4)
- **PC4** Cutterhead Lock Handle
- **PC8** M6 Split Lock Washer (2)



# ASSEMBLY

**⚠ WARNING:** To reduce the risk of injury, turn unit off and disconnect the machine from power source before installing and removing accessories, before adjusting and when making repairs. An accidental start-up can cause injury.

## ASSEMBLY TOOLS REQUIRED

T-Handle T30 Torx Wrench **PC5** (Supplied)

## ATTACHING THE CUTTERHEAD LOCK HANDLE

See Figure 3.

1. Use the supplied T-Handle T30 Torx Wrench **PC5** to attach the cutterhead lock handle **PC4** to the shaft **A** with the M6 x 20mm Torx Head Screw **PC6** and M6 Split Lock Washer **PC8**.

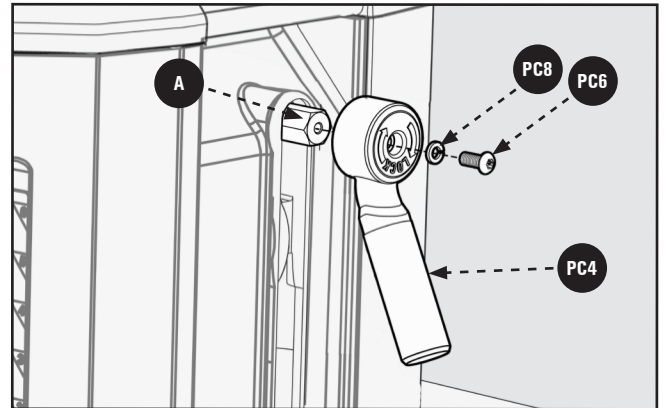

FIGURE 3

---

## ATTACHING THE CUTTERHEAD HEIGHT ADJUSTING HANDLE

See Figure 4.

1. Attach the cutterhead height adjusting handle **PC3** to the shaft **B**, aligning the flat edge of the shaft with the flat edge in the handle.
2. Fasten the cutterhead height adjusting handle to the shaft using the M6 x 20mm Torx Head Screw **PC6** and M6 Split Lock Washer **PC8** with the supplied T-Handle T30 Torx Wrench **PC5**.

**NOTE:** The cutterhead height adjusting handle is supplied with markings on the dial to make your cuts accurate.

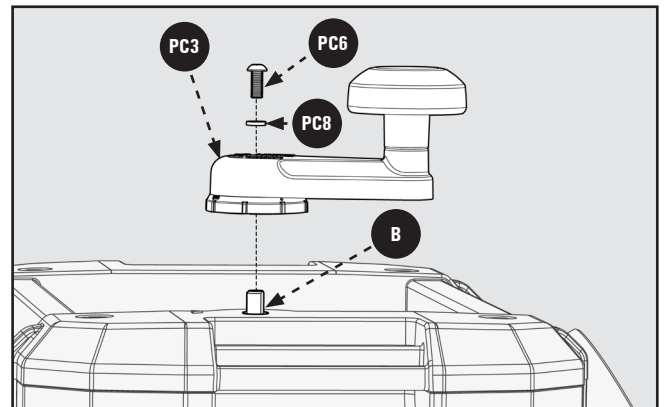

FIGURE 4

# ASSEMBLY

## PREPARING FOR DUST MANAGEMENT

You have two options for dust management. The first is the dust deflector and the second is the dust collection attachment to attach your machine to a dust collector.

**NOTE:** The dust deflector comes factory installed and can be used if the user elects not to use a dust collector system.

## INSTALLING THE DUST COLLECTION ATTACHMENT

**⚠ WARNING:** ALWAYS disconnect the machine from the power source before removing or installing any attachment or accessory.

1. Using the cutterhead height adjusting handle **PC3**, raise the main housing up high enough to allow clearance for the T-Handle T30 Torx Wrench **PC5**.
2. Using the wrench provided, remove the two M6 x 20mm Torx screws **PC6** and flat washers **PC7** that secure the dust deflector **F11**. Save these for step 4. See Figures 5 & 6.
3. Remove the dust deflector **F11**. See Figure 7.
4. Align the four slots in the dust collection attachment **F17** with holes in the frame, see Figure 8. Secure using four M6 x 20mm Torx screws **PC6** and flat washers **PC7** (two from step 2).
5. Reverse the procedure to reinstall the dust deflector. Install the dust deflector with the label up and curved lip pointing down.
6. Store the extra mounting screws with the dust collection attachment when it is not in use.

**⚠ CAUTION** When using the dust collection attachment, **DO NOT** operate the unit without a hose connected and a dust collector in operation. The dust collection attachment is designed to accept a 4 inch hose. **ALWAYS** replace the dust deflector when the dust collection attachment is not in use.

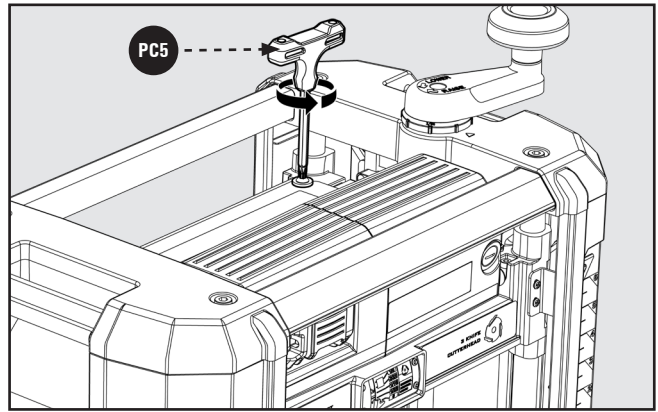

FIGURE 5

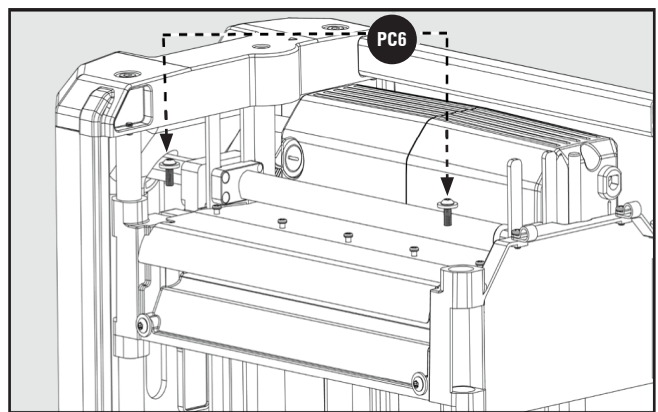

FIGURE 6

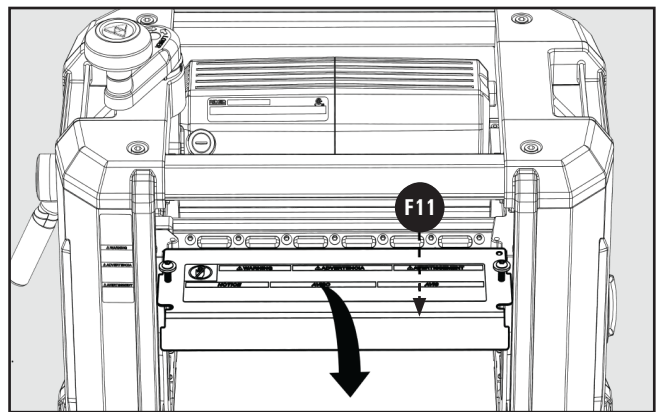

FIGURE 7

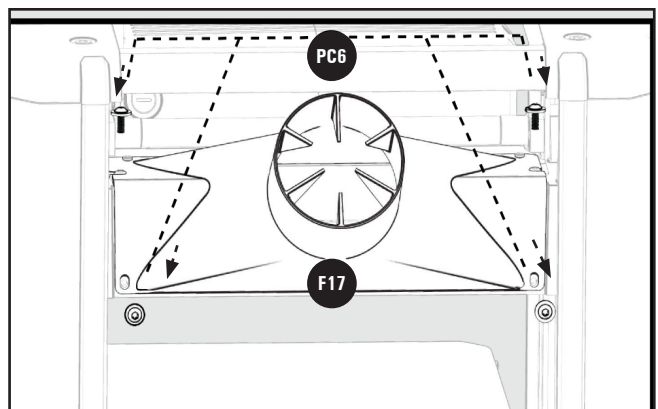

FIGURE 8

# ASSEMBLY

## FASTENING THE PLANER TO A SUPPORTING SURFACE

**⚠ WARNING:** Before operation, secure the planer to the supporting surface.

**⚠ WARNING:** Operate the planer on a flat, level surface.

1. Four mounting holes **A** are provided for mounting the planer to a stand or work surface. These holes are located under the in-feed and out-feed tables (two of which are shown in Figure 9).

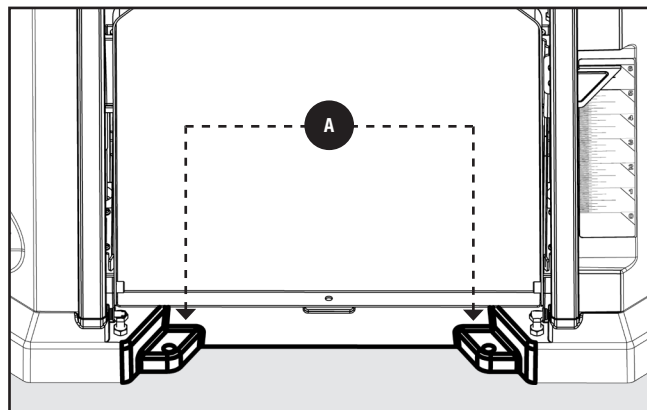

FIGURE 9

# OPERATION

## STARTING AND STOPPING THE PLANER

See Figures 10 & 11.

1. To turn the planer "ON", lift the paddle **F9**. To turn the tool "OFF", push the paddle down.

**IMPORTANT:** When the machine is not in use, the switch should be locked in the "OFF" position, see Figure 11, to prevent unauthorized use. Place a padlock **A** with a 1/4 inch (6.3mm) diameter shackle through the hole on the left side of the switch cover and through the hole in the switch paddle. Lock the padlock. See Figure 12.

**⚠ WARNING:** Ensure the lock is inserted in the holes correctly which will prevent the switch from being turned on.

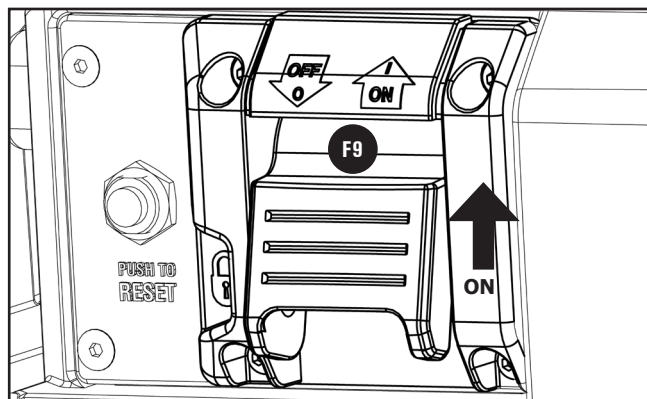

FIGURE 10

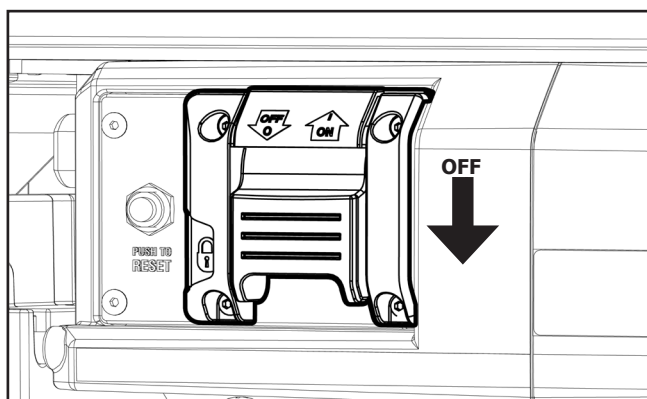

FIGURE 11

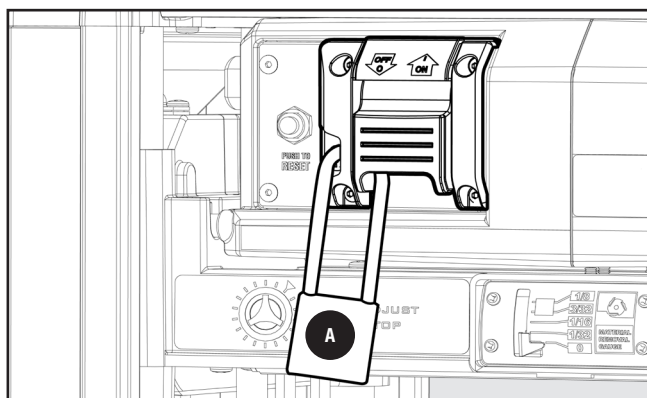

FIGURE 12

# OPERATION

## USING THE CUTTERHEAD LOCK

The cutterhead lock **PC4**, see Figure 13, prevents the cutterhead depth from being able to change. This helps to eliminate snipe in the board that is being planed. Snipe can also be eliminated by butting boards end to end and feeding them through the planer. Long boards should **ALWAYS** be supported, when feeding them through the planer to help eliminate snipe.

**NOTE:** To lock the cutterhead, turn handle clockwise. To unlock, turn handle counterclockwise.

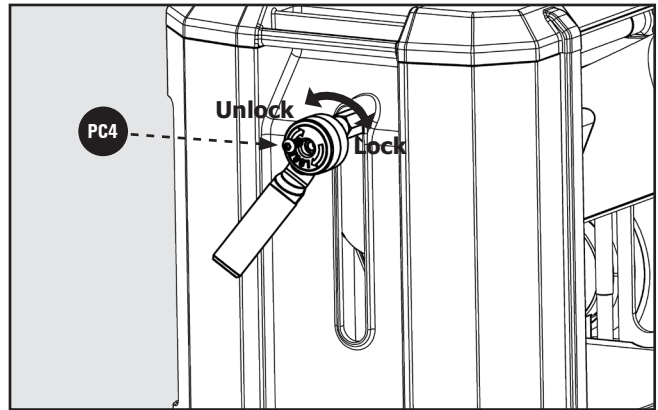

FIGURE 13

## ADJUSTING THE HEAD ASSEMBLY

The main housing contains the cutterhead, feed rollers, dust deflector and motor. Raising and lowering the main housing controls the depth of cut.

1. To adjust the main housing, unlock the cutterhead lock handle **PC4**, see Figure 13. Turn the cutterhead height adjusting handle **PC3** clockwise to raise or counterclockwise to lower the cutterhead. One revolution of the handle in Figure 14 will move the cutterhead up or down 1/16 inch (1.6mm). Once the cutterhead is at the desired height, lock the cutterhead assembly in place by engaging the cutterhead lock handle.

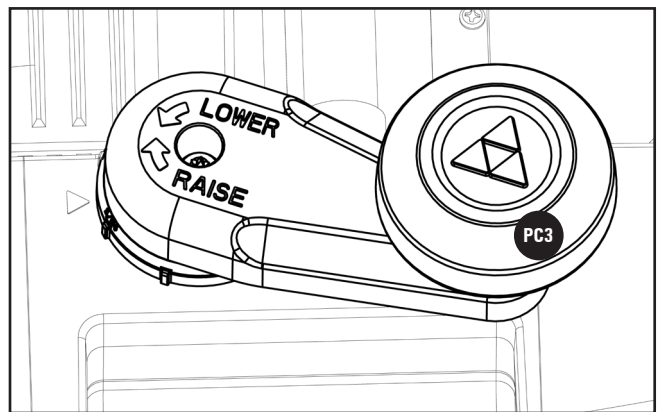

FIGURE 14

## USING THE MATERIAL REMOVAL GAUGE

See Figure 15.

Your planer is equipped with a material removal gauge **A**. It is used to indicate the amount of wood that will be removed in one pass with the carriage set at its current height. The material removal gauge reads across the entire width of the planer head.

1. Slide approximately 3 inches of the workpiece **B** under the carriage.
2. Be sure that the workpiece is lying flat against the table of the planer. If the workpiece is inserted at an angle, the reading may be inaccurate.
3. Lower the carriage on the workpiece until the material removal bar engages the wood. You will see the red arrow **A** moving up the scale to indicate the amount to be removed with the carriage at that height.
4. Adjust the carriage height until the desired depth of cut appears on the gauge.

**NOTE:** Record this depth as you may have to back the cutterhead off the board to allow you to remove it. Once this is done, pull the material out from under the carriage and reset the cutterhead to the desired depth.

5. Turn the unit on and feed your material into the cutter head.

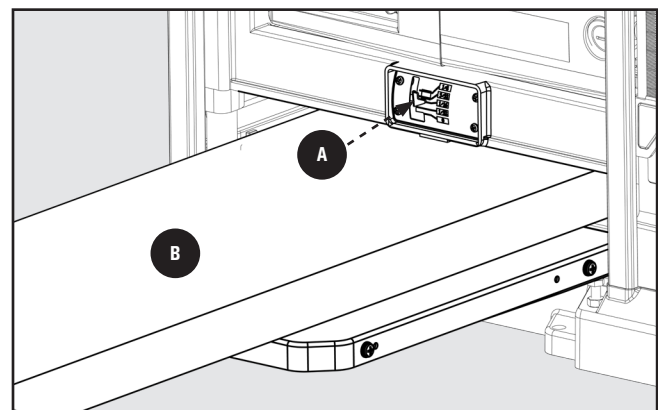

FIGURE 15

# OPERATION

**NOTE: DO NOT** exceed the recommended depth of cut for various widths of material, shown in the "RECOMMENDED DEPTH OF CUT" section below.

**⚠ WARNING:** **DO NOT** turn the unit "ON" with the workpiece in position.

## RECOMMENDED DEPTH OF CUT

See Figure 16.

**NOTE:** One revolution of the cutterhead height adjusting handle will move the cutterhead up or down 1/16 inch (1.6mm).

You can make a 1/8 inch (3.2mm) depth-of-cut in soft woods up to 6 inch (152mm) wide and in hard woods up to 4 inch (102mm) wide.

For 6 inch (152mm) through 13 inch (330mm) wide soft wood, use a maximum depth-of-cut of 1/16 inch (1.6mm). For 4 inch (102mm) through 13 inch (330mm) wide hard wood, use a maximum depth-of-cut of 3/64 inch (1.2mm).

**IMPORTANT:** A shallow depth-of-cut will produce a better finish.

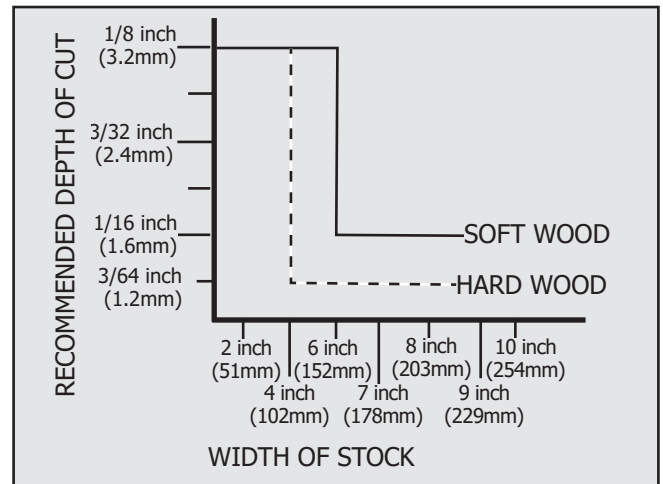

FIGURE 16

## USING THE DEPTH STOP

Your planer is equipped with a depth stop dial for repetitive planing, as shown in Figure 17. Any thickness between 1/8 inch and 1 1/4 inch can be selected using the scale on the depth stop. Detents are provided at 1/8 inch, 1/4 inch, 1/2 inch, 3/4 inch, 1 inch, and 1 1/4 inch.

To set the maximum depth (or minimum thickness) to which the cutterhead can travel with the depth stop:

1. Check to see that the cutterhead is set above 1 1/4 inch before trying to set the depth stop.
2. Make sure dial **F7** is unlocked by rotating the locking knob **B** counterclockwise.
3. Turn the dial **F7** to the desired thickness setting so that it aligns with the indicator line **A**, as shown in Figure 17.
4. Lock the gauge in place by turning the locking knob **B** clockwise, as shown in Figure 17.
5. Plane the workpiece at desired increments until the correct final thickness is achieved.

**NOTE: DO NOT** use force to lower the carriage below the level that the depth stop indicates. This will result in permanent damage to the height adjustment system on your planer.

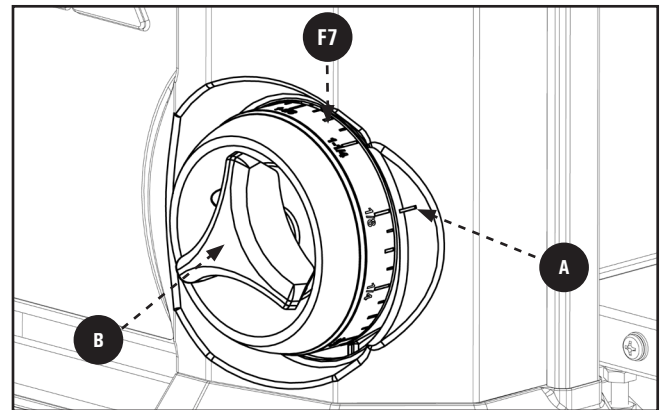

FIGURE 17

# OPERATION

## USING THE ADJUSTABLE INDEXING RING

The cutterhead height adjusting handle has an adjustment ring Figure 18. The Adjustable Index Ring is best utilized after the initial cut has been made.

To use the adjustment ring to make fine adjustments:

1. Once the initial cut has been made and fine tuning is required, measure the thickness of the planed board.
2. Set the ring **A** Figure 18 to align the zero with the arrow **B**.
3. Unlock the Cutterhead Lock Handle and rotate the handle to the desired depth of cut, as indicated on the ring. Each indicator on the ring is equivalent to 1/128 inch (.2mm) for making minute cuts.
4. Plane the workpiece and then repeat this process until you reach the final desired thickness.

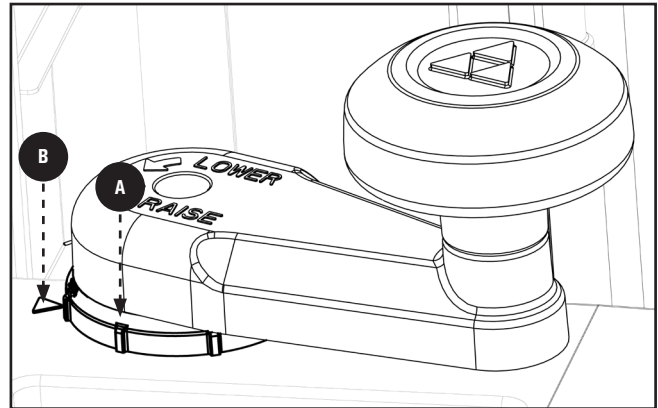

FIGURE 18

Follow these few steps to achieve the best results.

1. True One Face – Feed one face of the board over a jointer, making thin cuts with each pass, until the entire surface is flat.
2. Plane to Thickness – Place the side you just surfaced in **STEP 1** face down and feed the board through the planer, plane until this side is flat. Then plane both sides of the board until you are satisfied with the thickness, making thin cuts, alternating sides with each pass. If, during the planing operation, you notice the board twisting, warping or bowing, repeat **STEP 1** and true one face.
3. When planing long stock, provide additional support to the in-feed and out-feed end of the workpiece.
4. **ALWAYS** engage the cutterhead lock before planing. Plane with the grain **ONLY**, and **KEEP** table clean. Occasionally, wax the table surface to reduce friction.
5. Cross-cut the workpiece to its final length.

**NOTE:** When ever possible, feed the wood through the planer at different places on the table to help eliminate uneven wear of the knives.

## MINIMUM/MAXIMUM WIDTH/HEIGHT/DEPTH

**NOTE: ALWAYS** plane in the direction of the grain. Support the workpiece adequately at all times. Planing material less than 3/4 inch wide is not recommended. If you must plane narrow material, group several pieces together and plane them as one wide workpiece whenever possible. The maximum depth of cut your planer can take in one pass is 1/8 inch (soft wood). **NEVER** attempt to modify your planer to take a deeper cut. Follow the recommended depth/width of cut guidelines shown in Figure 16 for best results.

## PROPER PLANING TECHNIQUES

1. Lower the carriage to the desired height for your first pass and lock the cutterhead using the Cutterhead Lock Handle.
2. Turn the unit on and feed the material into the feed rollers.
3. Examine the cut and adjust the carriage to the appropriate height for your next pass.
4. When possible feed workpieces through alternating areas of the planer for even blade wear – not just through the center of the machine. One way to do this is to start with the workpiece on the left for the first pass, in the middle on the next and on the right side for third pass – and then repeat.

**NOTE:** Flip the board over between each pass.

**⚠ WARNING DO NOT** turn the unit on with the workpiece inserted under cutterhead. Wait until the roller and cutterhead are up to full speed before feeding your material into the machine.

For best results, plane both sides of the workpiece to reach desired thickness. For example, if you need to remove 1/8 inch from your workpiece, remove 1/16 inch from each side. This not **ONLY** allows the workpiece to dry with an even moisture content, it also produces finer cuts.

**⚠ WARNING** Plane **ONLY** wood that is free from foreign objects, with no loose knots and as few tight knots as possible. **DO NOT** plane wood that is severely warped, twisted, knotted or bowed.

**⚠ WARNING DO NOT** place your body between the rear of the planer and a stationary object while material is feeding. Serious injury could result.

# OPERATION

## SNIPE

Snipe is a depression made when an unsupported end of your material drops toward the floor, causing the opposite end to lift up into the cutter head.

## TO AVOID SNIPE

- Feed the workpiece into the planer so it is level and remains flat against the table at all times.
- **KEEP** the workpiece level throughout planing operation by receiving or “catching” it from the rear of the planer. If you are planing material that is especially long, the use of additional material support is recommended.

## TWISTED, CUPPED AND BOWED WOOD

If both sides of your material are very rough or if the material is cupped, bowed or twisted, your planer may not produce the desired result. Ideally, you should have at least one flat surface/face on your material before you plane. Your thickness planer will work best with material that has been run through a jointer to produce one flat surface. If you **DO NOT** have at least one flat surface or a jointer, see the following recommendations.

## TO PLANE TWISTED WOOD

**⚠ WARNING:** Twisted wood may jam your planer. If a jam occurs, turn the power “OFF”, disconnect the power supply and raise the cutterhead to release the workpiece from the cutter.

If your material is only **SLIGHTLY** twisted, plane both sides alternating from one to the other until the desired thickness is reached.

## TO PLANE CUPPED WOOD

To obtain the best possible results with cupped wood, rip the material down the middle and plane it as two separate pieces. Ripping the material reduces the severity of the cup and allows the machine to deliver better results. Understand that you will have to remove more material on cupped wood to achieve the desired thickness than you would on a normal board. If ripping the material is not an option, plane one side of the material until flat, then plane the opposite side until it is also flat. Start with the cupped portion of the board facing down.

**NOTE: DO NOT** flip the board back and forth between each pass as recommended by the general planing directions.

## TO PLANE BOWED WOOD

The feed rollers and cutter head in your planer will push the bow out of the material as it feeds. However, when the material exits the planer, the pressure of the rollers and cutterhead will release allowing the wood to spring back into a bowed formation. To properly remove the bow, use a jointer.

# MAINTENANCE/ADJUSTMENTS

**⚠ WARNING:** To reduce the risk of injury, turn unit off and disconnect the machine from power source before installing and removing accessories, before adjusting or when making repairs. An accidental start-up can cause injury.

**⚠ WARNING:** Wear gloves when you remove the knives for sharpening or replacement. The knives in this planer are very sharp.

**⚠ WARNING:** The knives are sharp. Be careful when removing, handling, or installing knives.

## CHECKING, ADJUSTING, CLEANING AND REPLACING KNIVES

The knives supplied with your planer are double edged and reversible so that you can turn the knives end-for-end when one edge becomes dull or chipped. To change the knives see Figures 19 - 22.

1. Raise the cutter head assembly to 4 inch (102mm) on the “Scale and Pointer”.
2. Remove the screws **A**. Pull the dust deflector or dust collection attachment – whichever is installed – **B** straight out.
3. Insert the supplied wrench **PC5** into the hex hole. Rotate the cutterhead until the cutterhead lock engages.
4. Remove the seven screws **E** and use magnetic end of the wrench to remove the hold-down bar **F**.

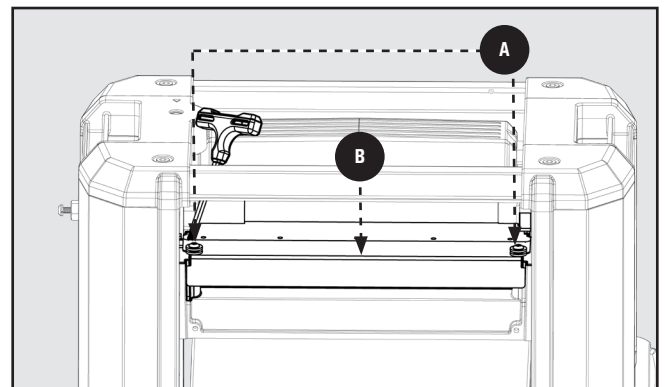

FIGURE 19

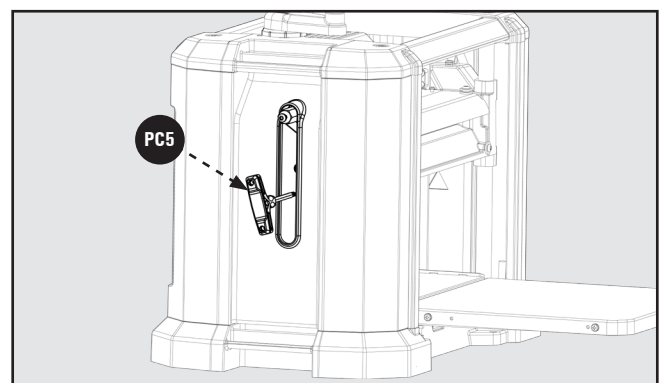

FIGURE 20

# MAINTENANCE/ADJUSTMENTS

5. Place the magnetized end of the wrench **PC5** at the center of the knife. Lift the wrench until the knife **H** separates from the pins. Remove the knife.
6. Repeat **STEPS 3** through **5** to remove the other two knives. Press down the cutterhead lock release **F15** and use the supplied wrench **PC5** to rotate the cutterhead until the lock engages and the next knife is in position to be removed.
7. **IMPORTANT:** After removing all knives from cutterhead, carefully set them aside. Using a cloth rag and isopropyl alcohol, carefully clean the cutterhead, knives and hold-down bars to remove all gum, tar and pitch residue. Take special care to clean the cutterhead under the knife area and the cutterhead radius in front of the knife area. Doing this will increase the life of your planer.

**⚠ WARNING** Remember to wear gloves while handling knives.

8. Take this time also to clean the rollers **I**, see Figure 23.
9. Your unit is equipped with double-edged knives. If the second edge of the knife has not been used, rotate the knife 180 degrees and replace on the cutterhead. Replace the knives if both sides have been used.
10. Attach the hold-down bar **F** Figure 21 that you removed in **STEP 4**. Tighten all fasteners securely **E**.
11. Depress the cutterhead lock release **F15** and rotate the cutterhead to the next empty position until the cutterhead lock engages.
12. Repeat steps 9 through 11 to replace the other knives.
13. Reattach the dust deflector or dust collection attachment.

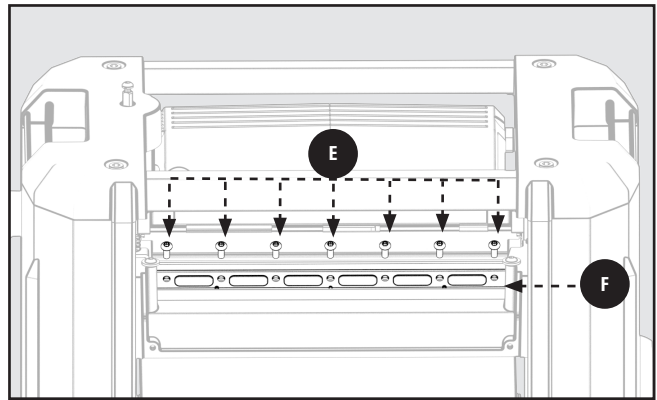

FIGURE 21

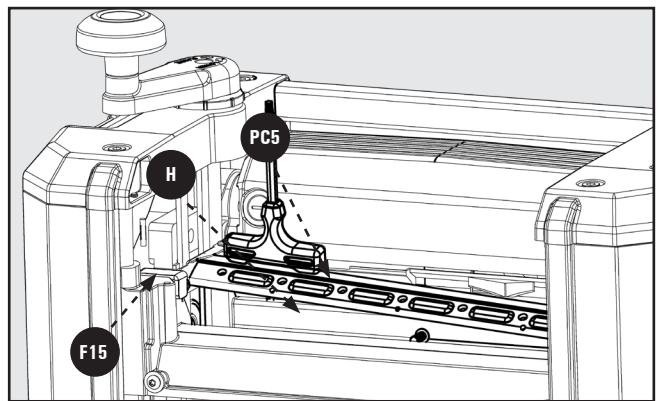

FIGURE 22

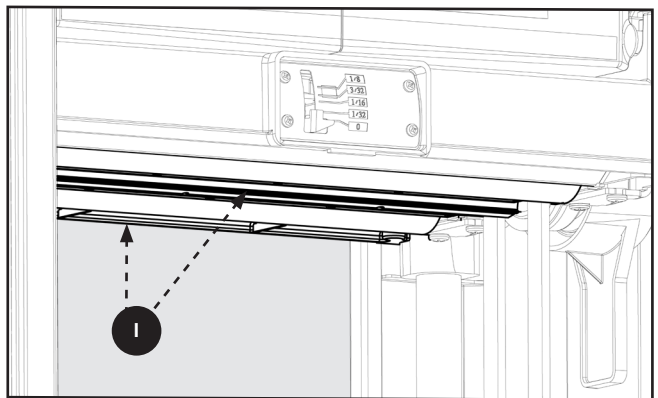

FIGURE 23



## ADJUSTING THE IN-FEED AND OUT-FEED TABLES

Your unit has been factory set with careful table alignment to help eliminate snipe. If your unit loses its adjustment and causes snipe, you can adjust the in-feed and out-feed tables to minimize this condition.

1. Raise the cutterhead.
2. Place a dime **A** Figure 24 at each end of the Wear Table (in-feed and out-feed).
3. Place a straight edge **B** across the two dimes. Extend the straight edge past the edges of the in-feed and out-feed tables.
4. If your tables are properly adjusted, the straight edge will touch both of the dimes and both the edges of the tables.
5. If your table needs adjustment, loosen the lock nuts **D** Figure 25 on the table height-adjustment screws **C**. Adjust the screws up or down to achieve the desired table height.
6. Make sure that both height-adjustment screws contact the bottom of the table after adjustment.
7. Re-tighten lock nuts **C**.

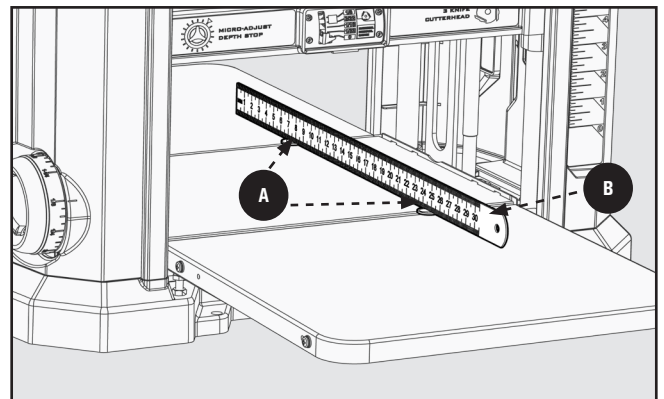

FIGURE 24

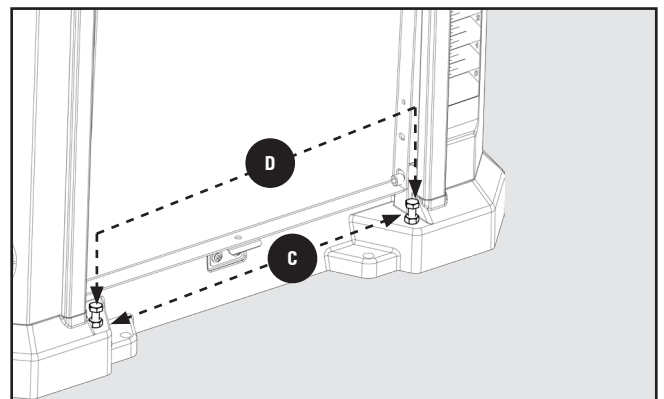

FIGURE 25

## CALIBRATING THE INDICATOR ARROW

The depth adjustment scale **F4**, Figure 26, on your planer is set at the factory. However, with extended use, the depth adjustment scale could show an incorrect measurement. To check the depth adjustment scale:

1. Plane a piece of scrap wood, noting the measurement on the depth adjustment scale.
2. Measure the finished thickness of the workpiece. When measuring the thickness, measure away from the ends. Beware of snipe. Measuring the snipe could result in inaccurate measurements.
3. If the thickness of the workpiece does not match the reading on the depth adjustment scale, loosen the two screws **B** on the red indicator. Adjust the pointer up or down until its reading matches the finished thickness of the workpiece. Securely re-tighten the screws.

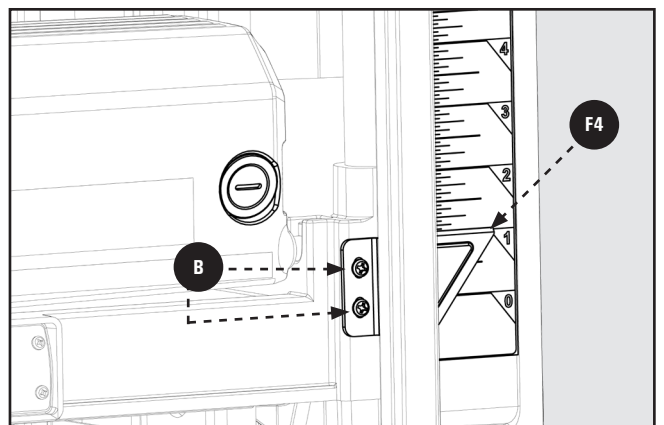

FIGURE 26

# MAINTENANCE/ADJUSTMENTS

## WEAR TABLE AND IN-FEED/ OUT-FEED TABLE MAINTENANCE

**KEEP** the tables clean and free from oil, grease, and pitch. Treat the tables with paste wax to help maintain its smooth finish.

## CIRCUIT BREAKER RESET BUTTON

Your planer is equipped with an 18 amp circuit breaker. If your planer becomes overloaded and stops operating, turn off the planer, let the unit sit for 2 minutes and press the reset button **F10** as shown in Figure 27 before you resume working.

**⚠ WARNING:** To prevent the planer from starting unexpectedly if power is interrupted by a circuit breaker trip, make sure the switch is in the "OFF" position before restoring power.

**NOTE:** Circuit breaker overload is often the result of dull knives. Change your knives on a regular basis to avoid tripping your breaker. Check your knives before re-setting the circuit breaker and continuing to plane.

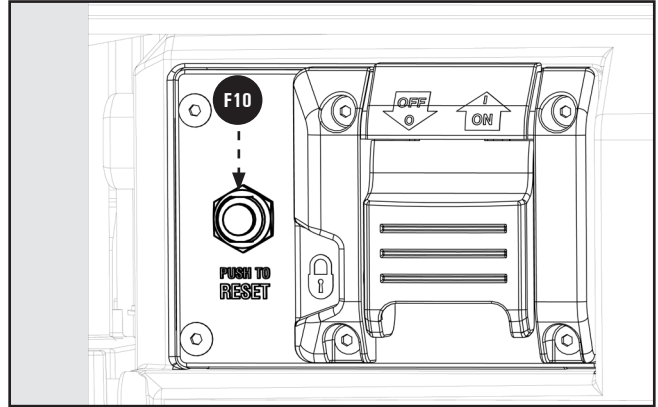

FIGURE 27

## BRUSH CHANGE

Your planer is equipped with replaceable motor brushes. If your brushes need to be replaced, remove brush caps **C** from motor housing Figure 28, and replace brushes.

**CAUTION:** For proper motor function use **ONLY** identical replacement brushes. For identical replacement brushes call DELTA® Customer Service at (toll free) 1-800-223-7278 or e-mail us at [www.deltamachinery.com](http://www.deltamachinery.com).

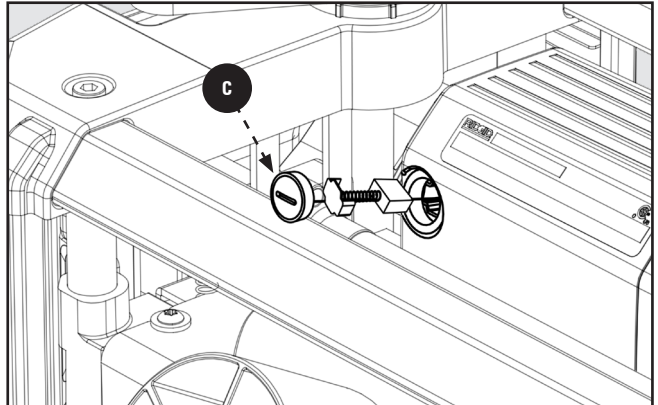

FIGURE 28

## REPLACING THE DRIVE BELT

Drive belts are wear items. To purchase replacement belts, call DELTA® Technical Service at (toll free) 1-800-223-7278.

## KEEP MACHINE CLEAN

Periodically blow out all air passages with dry compressed air. All plastic parts should be cleaned with a soft damp cloth. **NEVER** use solvents to clean plastic parts. They could possibly dissolve or otherwise damage the material.

**⚠ WARNING:** Wear certified safety equipment for eye, hearing and respiratory protection while using compressed air.

## LUBRICATION

Apply household floor paste wax to the machine table, extension table and other work surface weekly. Or use a commercially available protective product designed for this purpose. Follow the manufacturer's instructions for use and safety.

# TROUBLESHOOTING

For assistance with your machine, visit our website at [www.deltamachinery.com](http://www.deltamachinery.com) for a list of service centers or call DELTA® Technical Service at (toll free) 1-800-223-7278.

## FAILURE TO START

If your machine fails to start, check to make sure the prongs on the power cord plug are making good contact in the receptacle, and check reset button on power switch housing. Also, check for blown fuses or open circuit breakers in your power line.

Problem	Possible Cause	Solution
Snipe (uneven cut on end of boards)	<ol style="list-style-type: none"> <li>1. Dull cutterhead blades</li> <li>2. Incorrectly butted stock</li> <li>3. Unit not mounted properly</li> <li>4. Work tables out of alignment</li> </ol>	<ol style="list-style-type: none"> <li>1. Replace or flip cutterhead blades</li> <li>2. Butt pieces end to end as you feed them into the planer</li> <li>3. Tighten mounting bolts</li> <li>4. Adjust work tables</li> </ol>
Torn grain	<ol style="list-style-type: none"> <li>1. Cutterhead depth too deep</li> <li>2. Workpiece fed against the grain</li> <li>3. Dull cutterhead blades</li> </ol>	<ol style="list-style-type: none"> <li>1. Reduce the depth of cut</li> <li>2. Feed opposite end of board first</li> <li>3. Replace or flip cutterhead blades</li> </ol>
Fuzzy/rough grain	<ol style="list-style-type: none"> <li>1. Moisture content high in work piece</li> <li>2. Dull cutterhead blades</li> <li>3. Cutterhead depth too deep</li> <li>4. Incorrect feeding spacing</li> </ol>	<ol style="list-style-type: none"> <li>1. Make sure wood is dry prior to planing</li> <li>2. Replace or flip cutterhead blades</li> <li>3. Reduce the depth of cut</li> <li>4a. Check for proper power supply</li> <li>4b. Check cord and plug for damage</li> <li>4c. Check motor brush condition</li> </ol>
Uneven depth of cut	<ol style="list-style-type: none"> <li>1. Cutterhead not level with Wear Table</li> <li>2. Inconsistent pressure from rollers</li> <li>3. Rollers have uneven wear</li> </ol>	<ol style="list-style-type: none"> <li>1. Adjust the height adjustment screws</li> <li>2-3. Contact local authorized Service Center</li> </ol>
Board thickness does not match depth scale indicator	<ol style="list-style-type: none"> <li>1. Depth scale out of adjustment</li> <li>2. Tables dirty</li> </ol>	<ol style="list-style-type: none"> <li>1. Adjust depth scale</li> <li>2. Clean and wax the tables</li> </ol>
Cutterhead height difficult to adjust	<ol style="list-style-type: none"> <li>1. Dirty Height Adjusting Mechanism</li> <li>2. Worn chain</li> </ol>	<ol style="list-style-type: none"> <li>1. Clean and lubricate the spindle</li> <li>2. Contact local authorized Service Center</li> </ol>
Will not start	<ol style="list-style-type: none"> <li>1. Not plugged in</li> <li>2. Blown Circuit Breaker</li> <li>3. Motor Failure</li> <li>4. Loose wire</li> <li>5. On/Off switch not working</li> <li>6. Motor overload</li> <li>7. Blown Fuse</li> </ol>	<ol style="list-style-type: none"> <li>1. Check power source</li> <li>2. Reset breaker, or contact a certified electrician</li> <li>3-6. Contact local authorized Service Center</li> <li>7. Replace fuse</li> </ol>
Interrupted operation	<ol style="list-style-type: none"> <li>1. Unit overloaded</li> <li>2. Circuit overloaded</li> <li>3. Worn brushes</li> </ol>	<ol style="list-style-type: none"> <li>1. Reduce the load on the unit</li> <li>2. Operate on independent circuit not connected to other appliances</li> <li>3. Replace brushes</li> </ol>

## ACCESSORIES

A complete line of accessories is available from your DELTA® Supplier, DELTA® Factory Service Centers, and DELTA® Authorized Service Centers. Please call DELTA® Customer Service at (toll free) 1-800-223-7278 or e-mail us at [www.deltamachinery.com](http://www.deltamachinery.com).

**▲ WARNING:** Since accessories other than those offered by DELTA® have not been tested with this product, use of such accessories could be hazardous. For safest operation, ONLY DELTA® recommended accessories should be used with this product.

# PARTS, SERVICE OR WARRANTY ASSISTANCE

All DELTA® Machines and accessories are manufactured to high quality standards and are serviced by a network of an Authorized Service Centers. To obtain additional information regarding your product or to obtain parts, service, warranty assistance, or the location of the nearest service center, please call 1-800-223-7278.

## Five Year Limited Warranty

**1. WHAT IS COVERED.** Delta Power Equipment Corporation ("Company") will, at its option, repair or replace this product, if purchased at retail in the United States or Canada and the product, with normal use, has proven to be defective in workmanship or material, subject to the conditions stated in this Limited Warranty. This Limited Warranty covers only materials and labor. All transportation costs are Customer's responsibility.

**2. WARRANTY PERIOD.** All warranty claims must be submitted within five years from the date of retail purchase. For all service parts and factory refurbished products, the warranty period is 180 days.

**3. HOW TO OBTAIN SERVICE.** To obtain warranty service, you must return the defective product, at your expense, to a service center authorized by Company to perform warranty service (a "Company Authorized Service Center") within the applicable warranty period, together with acceptable proof of purchase, such as your original receipt bearing the date of purchase, or product registration number. Company reserves the right to restrict warranty claim service to the country where the purchase was made and/or to charge for the cost to export service parts or provide warranty service in a different country. For this purpose, on-line purchases are deemed made in the United States. For the location of your nearest Company Authorized Service Center, call Company's Customer Care Center at (800) 223-7278.

### 4. EXCLUSIONS:

- Company does not offer any warranty on products purchased in used or damaged condition.
- Company does not warrant any products purchased outside the United States or Canada
- Company will not be responsible for any damage that has resulted from normal wear, misuse, abuse or any repair or alteration made by anyone other than a Company Authorized Service Center or a designated representative of Company's Customer Care Center.

**All IMPLIED WARRANTIES** are expressly limited to the warranty period identified above.

**Company will not be liable for INCIDENTAL OR CONSEQUENTIAL** damages.

This limited warranty is Company's sole warranty and sets forth the customer's exclusive remedy with respect to defective products; all other warranties, express or implied, whether of merchantability, fitness for purpose, or otherwise, are expressly disclaimed by Company, except as expressly stated in this warranty statement.

Some states do not allow the exclusion or limitation of incidental or consequential damages, or the limitation of implied warranties, so the above limitations or exclusions may not apply to you. This warranty gives you specific legal rights and you may have other rights which vary in certain states or provinces. For further details of warranty coverage and warranty repair information, call (800) 223-7278.

**LATIN AMERICA:** This warranty does not apply to products sold in Latin America. For products sold in Latin America, call the local company or see website for warranty information.

## REPLACEMENT PARTS

Use only identical replacement parts. For a parts list or to order parts, visit our website at [www.DeltaMachinery.com/service](http://www.DeltaMachinery.com/service). You can also order parts from your nearest Authorized Warranty Service Center or by calling Technical Service Manager at 1-800-223-7278 to receive personalized support from one of our highly-trained representatives.

## FREE WARNING LABEL REPLACEMENT

If your warning labels become illegible or are missing, call 1-800-223-7278 for a free replacement.

## SERVICE AND REPAIRS

All quality tools will eventually require servicing and/or replacement of parts. For information about Delta Power Equipment Corporation, its factory-owned branches, or to locate an Authorized Warranty Service Center, visit our website at [www.DeltaMachinery.com/service](http://www.DeltaMachinery.com/service) or call Customer Care at 1-800-223-7278. All repairs made by our service centers are fully guaranteed against defective material and workmanship. We cannot guarantee repairs made or attempted by others. By calling this number you can also find answers to most frequently asked questions 24 hours/day. You can also write to us for information at Delta Power Equipment Corporation, 2651 New Cut Road, Spartanburg, SC 29303 - Attention: Technical Service Manager. Be sure to indicate all of the information shown on the nameplate of your saw (model number, type, serial number, date code, etc.).

**2651 New Cut Road  
Spartanburg, SC 29303  
(800) 223-7278  
[www.DeltaMachinery.com](http://www.DeltaMachinery.com)**

©2022 Delta Power Equipment Corporation

DPEC005377

Rev:3

07/27/2022

