



POWER EQUIPMENT CORPORATION

AFM-28
PART # DPEC001372
DATE: 01-25-12
REVISED: 10-26-22

31-140

12 in. DISC SANDER

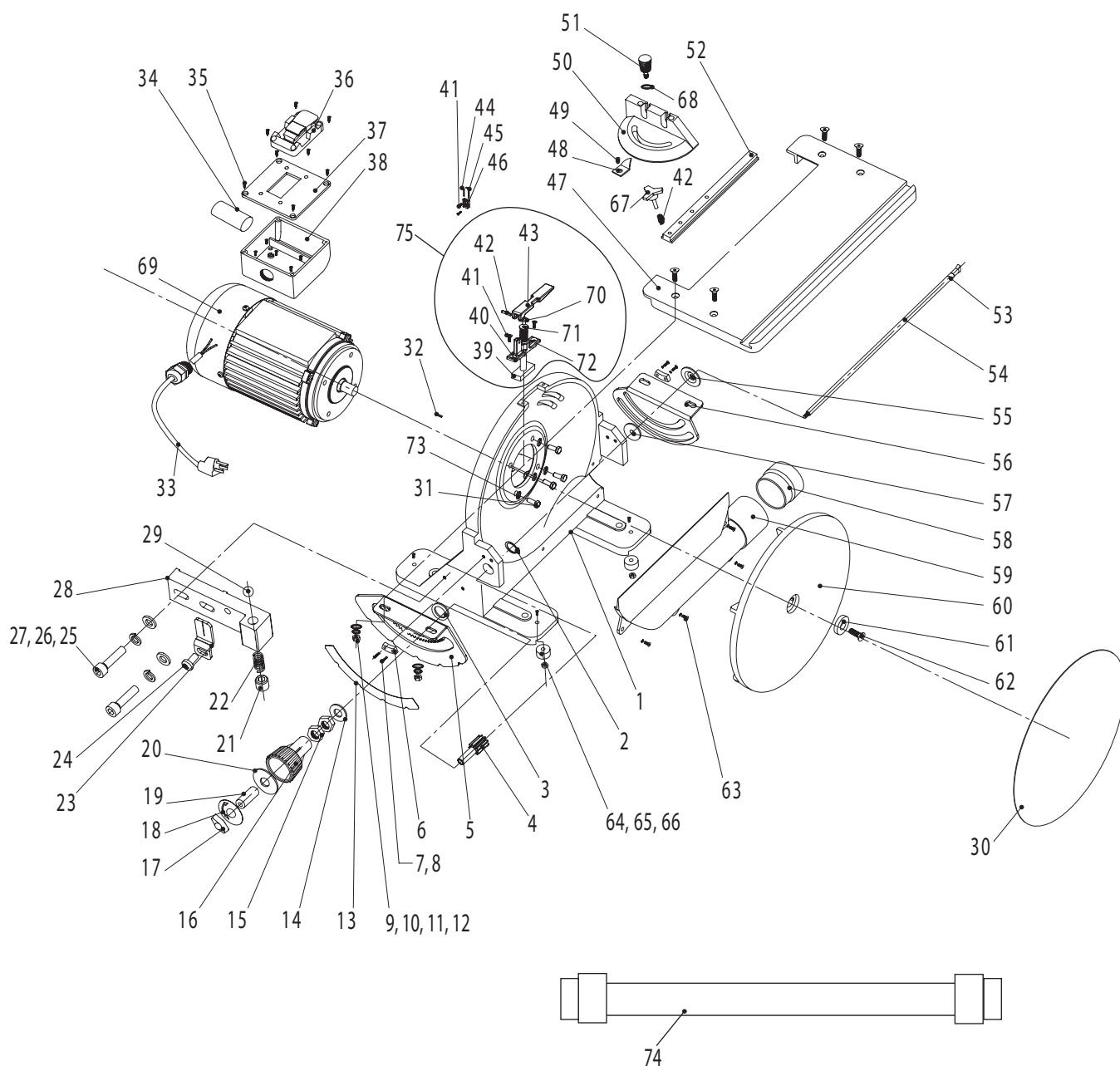

REPLACEMENT PARTS

NO.	DELTA PART NO.	DESCRIPTION	Q'TY	NO.	DELTA PART NO.	DESCRIPTION	Q'TY
1	DPEC001293	Base	1	38	DPEC001330	Switch Box	1
2	DPEC001294	Retaining Ring 17MM	1	39	DPEC001331	Brake Pad	1
3	DPEC001295	M18 Washer	1	40	DPEC001332	Brake Bracket	1
4	DPEC001296	Gear Shaft	1	41	DPEC001333	* M4 X 8 Screw	5
5	DPEC001297	Front Trunnion	1	42	DPEC001334	Brake Spring 4X12	1
6	DPEC001298	Guide Shaft	2	43	DPEC001335	Brake Lever	1
7	DPEC001299	* M5 X 20 Hex Nut	4	44	DPEC001336	* 2.5MM L Wrench	1
8	DPEC001300	* M5 Spring Washer	4	45	DPEC001337	* 4 MM L Wrench	1
9	DPEC001301	* M6 X 20 Screw	4	46	DPEC001338	Tool Holder	1
10	DPEC001302	* M6 Washer	4	47	DPEC001339	Table	1
11	DPEC001303	* M6 Spring Washer	4	48	DPEC001340	Pointer	1
12	DPEC001304	* M6 Hex Nut	4	49	DPEC001341	* M5 X 6 Screw	1
13	DPEC001305	Scale	1	50	DPEC001342	Miter Gauge Body	1
14	DPEC001306	* M10 Washer	1	51	DPEC001343	Lock Knob	1
15	DPEC001307	* M10 Hex Nut	2	52	DPEC001344	Guide Block	1
16	DPEC001308	Adjusting Handle	1	53	DPEC001345	* Rubber O-Ring	2
17	DPEC001309	Lock Knob	1	54	DPEC001346	Lock Shaft	1
18	DPEC001310	Lock Label	1	55	DPEC001347	Washer A	1
19	DPEC001311	Adjusting Tube	1	56	DPEC001348	Rear Trunnion	1
20	DPEC001312	Handle Cap	1	57	DPEC001349	* M6 Washer	1
21	DPEC001313	* M10 X 8 Set Screw	1	58	DPEC001350	Dust Port	1
22	DPEC001314	Spring	1	59	DPEC001351	Plastic Shield	1
23	DPEC001315	Pointer	1	60	DPEC001352	Disc Body	1
24	DPEC001316	* M5 X 10 Screw	1	61	DPEC001353	Washer B	1
25	DPEC001317	* M6 X 25 Bolt	2	62	DPEC001354	* M6 X 16 Screw	1
26	DPEC001318	* M6 Washer	2	63	DPEC001355	* M5 X 10 Screw	4
27	DPEC001319	* M6 Spring Washer	2	64	DPEC001356	* M6 X 16 Screw	4
28	DPEC001320	Mounting Base	1	65	DPEC001357	* M6 Nut	4
29	DPEC001321	Ball 8mm	1	66	DPEC001358	M6 Rubber Washer	4
30	DPEC001322	Disc	1	67	DPEC001359	Hex Nut	1
31	DPEC001323	* M8 X 20 Hex screw	4	68	DPEC001360	* M6 Washer	1
32	DPEC001324	Flat Bolt	1	69	DPEC001361	Motor	1
33	DPEC001325	Power Cord	1	70	DPEC001362	* M4 X 5mm Screw	1
34	DPEC001326	Capacitor	1	71	DPEC001363	* M4 Washer	1
35	DPEC001327	Screw	7	72	DPEC001364	Brake spring	1
36	DPEC001328	Switch	1	73	DPEC001365	* M8 Spring Washer	4
37	DPEC001329	Cover for Switch Box	1	74	DPEC004432	Attachment Hose	1
				75	DPEC007291	Brake Assembly	1

* = Item is standard hardware and can be purchased at local hardware or home improvement stores.