

STOCK FEEDERS

Models 36-851, 36-852,
36-855, and 36-856

Models 36-851 single phase
& 36-852 three phase



Models 36-855 single phase
& 36-856 three phase

PART NO. A08479 - 05-31-05
Copyright © 2005 Delta Machinery



To learn more about DELTA MACHINERY
visit our website at: www.deltamachinery.com.

For Parts, Service, Warranty or other Assistance,
please call **1-800-223-7278** (In Canada call **1-800-463-3582**).

TABLE OF CONTENTS

IMPORTANT SAFETY INSTRUCTIONS2
SAFETY GUIDELINES3
GENERAL SAFETY RULES4
ADDITIONAL SPECIFIC SAFETY RULES5
FUNCTIONAL DESCRIPTION7
CARTON CONTENTS7
ASSEMBLY7
OPERATION8
TROUBLESHOOTING12
MAINTENANCE12
SERVICE13
ACCESSORIES13
WARRANTY14
SERVICE CENTER LOCATIONSback cover

IMPORTANT SAFETY INSTRUCTIONS

▲ WARNING Read and understand all warnings and operating instructions before using any tool or equipment. When using tools or equipment, basic safety precautions should always be followed to reduce the risk of personal injury. Improper operation, maintenance or modification of tools or equipment could result in serious injury and property damage. There are certain applications for which tools and equipment are designed. Delta Machinery strongly recommends that this product NOT be modified and/or used for any application other than for which it was designed.

If you have any questions relative to its application DO NOT use the product until you have written Delta Machinery and we have advised you.

Online contact form at www.deltamachinery.com

Postal Mail: Technical Service Manager
Delta Machinery
4825 Highway 45 North
Jackson, TN 38305

(IN CANADA: 125 Mural St. Suite 300, Richmond Hill, ON, L4B 1M4)

Information regarding the safe and proper operation of this tool is available from the following sources:

Power Tool Institute
1300 Sumner Avenue, Cleveland, OH 44115-2851
www.powertoolinstitute.org

National Safety Council
1121 Spring Lake Drive, Itasca, IL 60143-3201

American National Standards Institute, 25 West 43rd Street, 4 floor, New York, NY 10036 www.ansi.org
ANSI 01.1 Safety Requirements for Woodworking Machines, and

the U.S. Department of Labor regulations www.osha.gov

SAVE THESE INSTRUCTIONS!

SAFETY GUIDELINES - DEFINITIONS

It is important for you to read and understand this manual. The information it contains relates to protecting YOUR SAFETY and PREVENTING PROBLEMS. The symbols below are used to help you recognize this information.



- ▲ DANGER** Indicates an imminently hazardous situation which, if not avoided, will result in death or serious injury.
- ▲ WARNING** Indicates a potentially hazardous situation which, if not avoided, could result in death or serious injury.
- ▲ CAUTION** Indicates a potentially hazardous situation which, if not avoided, may result in minor or moderate injury.
- CAUTION** Used without the safety alert symbol indicates potentially hazardous situation which, if not avoided, may result in property damage.

CALIFORNIA PROPOSITION 65

▲ WARNING **SOME DUST CREATED BY POWER SANDING, SAWING, GRINDING, DRILLING, AND OTHER CONSTRUCTION ACTIVITIES** contains chemicals known to cause cancer, birth defects or other reproductive harm.

Some examples of these chemicals are:

- lead from lead-based paints,
- crystalline silica from bricks and cement and other masonry products, and
- arsenic and chromium from chemically-treated lumber.

Your risk from these exposures varies, depending on how often you do this type of work. To reduce your exposure to these chemicals: work in a well ventilated area, and work with approved safety equipment, always wear **NIOSH/OSHA** approved, properly fitting face mask or respirator when using such tools.

GENERAL SAFETY RULES



⚠ WARNING READ AND UNDERSTAND ALL WARNINGS AND OPERATING INSTRUCTIONS BEFORE USING THIS EQUIPMENT. Failure to follow all instructions listed below, may result in electric shock, fire, and/or serious personal injury or property damage.

IMPORTANT SAFETY INSTRUCTIONS

- FOR YOUR OWN SAFETY, READ THE INSTRUCTION MANUAL BEFORE OPERATING THE MACHINE.** Learning the machine's application, limitations, and specific hazards will greatly minimize the possibility of accidents and injury.
- WEAR EYE AND HEARING PROTECTION. ALWAYS USE SAFETY GLASSES.** Everyday eyeglasses are NOT safety glasses. USE CERTIFIED SAFETY EQUIPMENT. Eye protection equipment should comply with ANSI Z87.1 standards. Hearing equipment should comply with ANSI S3.19 standards.
- WEAR PROPER APPAREL.** Do not wear loose clothing, gloves, neckties, rings, bracelets, or other jewelry which may get caught in moving parts. Nonslip footwear is recommended. Wear protective hair covering to contain long hair.
- DO NOT USE THE MACHINE IN A DANGEROUS ENVIRONMENT.** The use of power tools in damp or wet locations or in rain can cause shock or electrocution. Keep your work area well-lit to prevent tripping or placing arms, hands, and fingers in danger.
- MAINTAIN ALL TOOLS AND MACHINES IN PEAK CONDITION.** Keep tools sharp and clean for best and safest performance. Follow instructions for lubricating and changing accessories. Poorly maintained tools and machines can further damage the tool or machine and/or cause injury.
- CHECK FOR DAMAGED PARTS.** Before using the machine, check for any damaged parts. Check for alignment of moving parts, binding of moving parts, breakage of parts, and any other conditions that may affect its operation. A guard or any other part that is damaged **should be properly repaired or replaced.** Damaged parts can cause further damage to the machine and/or injury.
- KEEP THE WORK AREA CLEAN.** Cluttered areas and benches invite accidents.
- KEEP CHILDREN AND VISITORS AWAY.** Your shop is a potentially dangerous environment. Children and visitors can be injured.
- REDUCE THE RISK OF UNINTENTIONAL STARTING.** Make sure that the switch is in the "OFF" position before plugging in the power cord. In the event of a power failure, move the switch to the "OFF" position. An accidental start-up can cause injury.
- USE THE GUARDS.** Check to see that all guards are in place, secured, and working correctly to reduce the risk of injury.
- REMOVE ADJUSTING KEYS AND WRENCHES BEFORE STARTING THE MACHINE.** Tools, scrap pieces, and other debris can be thrown at high speed, causing injury.
- USE THE RIGHT MACHINE.** Don't force a machine or an attachment to do a job for which it was not designed. Damage to the machine and/or injury may result.
- USE RECOMMENDED ACCESSORIES.** The use of accessories and attachments not recommended by Delta may cause damage to the machine or injury to the user.
- USE THE PROPER EXTENSION CORD.** Make sure your extension cord is in good condition. When using an extension cord, be sure to use one heavy enough to carry the current your product will draw. An undersized cord will cause a drop in line voltage, resulting in loss of power and overheating. See the Extension Cord Chart for the correct size depending on the cord length and nameplate ampere rating. If in doubt, use the next heavier gauge. The smaller the gauge number, the heavier the cord.
- SECURE THE WORKPIECE.** Use clamps or a vise to hold the workpiece when practical. Loss of control of a workpiece can cause injury.
- FEED THE WORKPIECE AGAINST THE DIRECTION OF THE ROTATION OF THE BLADE, CUTTER, OR ABRASIVE SURFACE.** Feeding it from the other direction will cause the workpiece to be thrown out at high speed.
- DON'T FORCE THE WORKPIECE ON THE MACHINE.** Damage to the machine and/or injury may result.
- DON'T OVERREACH.** Loss of balance can make you fall into a working machine, causing injury.
- NEVER STAND ON THE MACHINE.** Injury could occur if the tool tips, or if you accidentally contact the cutting tool.
- NEVER LEAVE THE MACHINE RUNNING UNATTENDED. TURN THE POWER OFF.** Don't leave the machine until it comes to a complete stop. A child or visitor could be injured.
- TURN THE MACHINE "OFF", AND DISCONNECT THE MACHINE FROM THE POWER SOURCE** before installing or removing accessories, before adjusting or changing set-ups, or when making repairs. An accidental start-up can cause injury.
- MAKE YOUR WORKSHOP CHILDPROOF WITH PADLOCKS, MASTER SWITCHES, OR BY REMOVING STARTER KEYS.** The accidental start-up of a machine by a child or visitor could cause injury.
- STAY ALERT, WATCH WHAT YOU ARE DOING, AND USE COMMON SENSE. DO NOT USE THE MACHINE WHEN YOU ARE TIRED OR UNDER THE INFLUENCE OF DRUGS, ALCOHOL, OR MEDICATION.** A moment of inattention while operating power tools may result in injury.
- ⚠ WARNING** USE OF THIS TOOL CAN GENERATE AND DISBURSE DUST OR OTHER AIRBORNE PARTICLES, INCLUDING WOOD DUST, CRYSTALLINE SILICA DUST AND ASBESTOS DUST. Direct particles away from face and body. Always operate tool in well ventilated area and provide for proper dust removal. Use dust collection system wherever possible. Exposure to the dust may cause serious and permanent respiratory or other injury, including silicosis (a serious lung disease), cancer, and death. Avoid breathing the dust, and avoid prolonged contact with dust. Allowing dust to get into your mouth or eyes, or lay on your skin may promote absorption of harmful material. Always use properly fitting NIOSH/OSHA approved respiratory protection appropriate for the dust exposure, and wash exposed areas with soap and water.

ADDITIONAL SPECIFIC SAFETY RULES

⚠ WARNING FAILURE TO FOLLOW THESE RULES MAY RESULT IN SERIOUS PERSONAL INJURY.

1. **DO NOT OPERATE THIS MACHINE** until it is completely assembled and installed according to the instructions. A machine incorrectly assembled can cause serious injury.
2. **OBTAIN ADVICE** from your supervisor, instructor, or another qualified person if you are not thoroughly familiar with the operation of this machine. Knowledge is safety.
3. **FOLLOW ALL WIRING CODES** and recommended electrical connections to prevent shock or electrocution.
4. **NEVER TURN THE MACHINE “ON”** before clearing the table/work area of all objects (tools, scraps of wood, etc.). Flying debris is dangerous.
5. **NEVER TURN THE MACHINE “ON”** with the workpiece contacting the stock feeder.
6. **AVOID AWKWARD OPERATIONS AND HAND POSITIONS.** A sudden slip could cause a hand to move into the stock feeder or the blade of the cutting machine.
7. **KEEP ARMS, HANDS, AND FINGERS** away from the rotating parts of feeder and cutting machine.
8. **ALLOW THE BLADE OF THE CUTTING MACHINE TO REACH FULL SPEED** before feeding a workpiece into the stock feeder.
9. **NEVER PERFORM LAYOUT,** assembly, or set-up work on the table/work area when the machine is running.
10. **TURN THE MACHINE “OFF” AND DISCONNECT THE MACHINE** from the power source before installing or removing accessories, before adjusting or changing set-ups, or when making repairs.
11. **TURN THE MACHINE “OFF”**, disconnect the machine from the power source, and clean the table/work area before leaving the machine. **LOCK THE SWITCH IN THE “OFF” POSITION** to prevent unauthorized use.
12. **ADDITIONAL INFORMATION** regarding the safe and proper operation of power tools (i.e. a safety video) is available from the Power Tool Institute, 1300 Sumner Avenue, Cleveland, OH 44115-2851 (www.powertoolinstitute.com). Information is also available from the National Safety Council, 1121 Spring Lake Drive, Itasca, IL 60143-3201. Please refer to the American National Standards Institute ANSI 01.1 Safety Requirements for Woodworking Machines and the U.S. Department of Labor OSHA 1910.213 Regulations.

SAVE THESE INSTRUCTIONS.
Refer to them often and use them to instruct others.

POWER CONNECTIONS

A separate electrical circuit should be used for your machines. This circuit should not be less than #12 wire and should be protected with a 20 Amp time lag fuse. If an extension cord is used, use only 3-wire extension cords which have 3-prong grounding type plugs and matching receptacle which will accept the machine's plug. Before connecting the machine to the power line, make sure the switch (s) is in the "OFF" position and be sure that the electric current is of the same characteristics as indicated on the machine. All line connections should make good contact. Running on low voltage will damage the machine.

⚠ DANGER DO NOT EXPOSE THE MACHINE TO RAIN OR OPERATE THE MACHINE IN DAMP LOCATIONS.

MOTOR SPECIFICATIONS

Your machine is wired for (see SPEC PLATE VOLTAGE), 60 HZ alternating current. Before connecting the machine to the power source, make sure the switch is in the "OFF" position.

GROUNDING INSTRUCTIONS

⚠ DANGER THIS MACHINE MUST BE GROUNDED WHILE IN USE TO PROTECT THE OPERATOR FROM ELECTRIC SHOCK.

3. Grounded, cord-connected machines intended for use on a supply circuit having a nominal rating between 150 - 250 volts, inclusive:

If the machine is intended for use on a circuit that has an outlet that looks like the one illustrated in Fig. C, the machine will have a grounding plug that looks like the plug illustrated in Fig. C. Make sure the machine is connected to an outlet having the same configuration as the plug. No adapter is available or should be used with this machine. If the machine must be re-connected for use on a different type of electric circuit, the re-connection should be made by qualified service personnel; and after re-connection, the machine should comply with all local codes and ordinances.

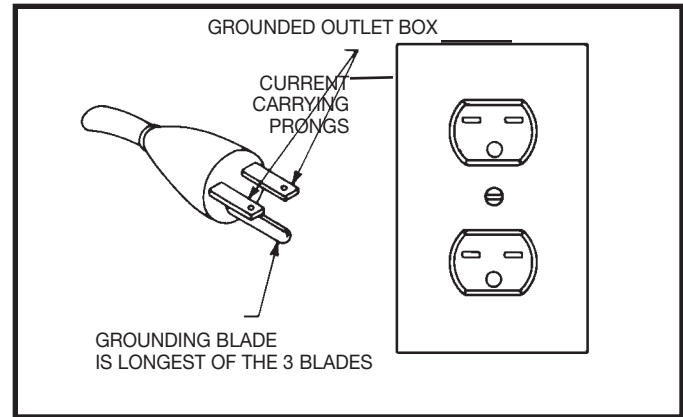

Fig. C

4. Permanently connected machines:

If the machine is intended to be permanently connected, the machine should be connected to a grounded metal permanent wiring system, or to a system having an equipment-grounding conductor.

THREE PHASE OPERATION

Three phase MACHINES are not supplied with a power cord. They must be permanently connected to the building electrical system and grounded according to the National Electrical Code. Since they must be permanently connected to the building electrical system, extension cords cannot be used with three phase MACHINES.

⚠ DANGER IN ALL CASES, MAKE CERTAIN THAT THE RECEPTACLE IN QUESTION IS PROPERLY GROUNDED. IF YOU ARE NOT SURE, HAVE A QUALIFIED ELECTRICIAN CHECK THE RECEPTACLE.

EXTENSION CORDS

⚠ WARNING Use proper extension cords. Make sure your extension cord is in good condition and is a 3-wire extension cord which has a 3-prong grounding type plug and matching receptacle which will accept the machine's plug. When using an extension cord, be sure to use one heavy enough to carry the current of the machine. An undersized cord will cause a drop in line voltage, resulting in loss of power and overheating. Fig. D-1 or D-2, shows the correct gauge to use depending on the cord length. If in doubt, use the next heavier gauge. The smaller the gauge number, the heavier the cord.

MINIMUM GAUGE EXTENSION CORD			
RECOMMENDED SIZES FOR USE WITH STATIONARY ELECTRIC MACHINES			
Ampere Rating	Volts	Total Length of Cord in Feet	Gauge of Extension Cord
0-6	240	up to 50	18 AWG
0-6	240	50-100	16 AWG
0-6	240	100-200	16 AWG
0-6	240	200-300	14 AWG
6-10	240	up to 50	18 AWG
6-10	240	50-100	16 AWG
6-10	240	100-200	14 AWG
6-10	240	200-300	12 AWG
10-12	240	up to 50	16 AWG
10-12	240	50-100	16 AWG
10-12	240	100-200	14 AWG
10-12	240	200-300	12 AWG
12-16	240	up to 50	14 AWG
12-16	240	50-100	12 AWG
12-16	240	GREATER THAN 100 FEET NOT RECOMMENDED	

FUNCTIONAL DESCRIPTION

FOREWORD

The Delta Model 36-851 four-speed, three-roller Stock Feeder is powered by a 1 hp, 240V, single-phase, reversing motor. This unit comes with 3 rubber feed rollers, vertical and horizontal support columns, universal joints, and a lubricating gun.

The Delta Model 36-852 four-speed, three-roller Stock Feeder is powered by a 1 hp, 230V, three-phase, reversing motor. This unit comes with 3 rubber feed rollers, vertical and horizontal support columns, universal joints, and a lubricating gun.

The Delta Model 36-855 eight-speed, four-roller Stock Feeder is powered by a 1 hp, 240V, single-phase, two-speed reversing motor. This unit comes with a two-speed gear lever, 4 rubber feed rollers, vertical and horizontal support columns, universal joints, and a lubricating gun.

The Delta Model 36-856 eight-speed, four-roller Stock Feeder is powered by a 1 hp, 230V, three-phase, two-speed reversing motor. This unit comes with a two-speed gear lever, 4 rubber feed rollers, vertical and horizontal support columns, universal joints, and a lubricating gun.

NOTICE: The photo on the manual cover illustrates the current production model. All other illustrations contained in the manual are representative only and may not depict the actual color, labeling, or accessories and are intended to illustrate technique only.

CARTON CONTENTS

1) Stock Feeder assembly

2) Vertical and horizontal support columns

3) Lubricating gun

UNPACKING AND CLEANING

Carefully unpack the machine and all loose items from the shipping container(s). Remove the protective coating from all unpainted surfaces. This coating may be removed with a soft cloth moistened with kerosene (do not use acetone, gasoline or lacquer thinner for this purpose). After cleaning, cover the unpainted surfaces with a good quality household floor paste wax.

ASSEMBLY

⚠ WARNING For your own safety, do not connect the machine to the power source until the machine is completely assembled and you read and understand the entire instruction manual.

ASSEMBLY TOOLS REQUIRED

3/8" Wrench
5/16" Wrench

7/16" Wrench
1/2" Wrench

4mm Hex Wrench
Phillips Screwdriver

ASSEMBLY TIME ESTIMATE

Approximately 2-4 hours

INSTALLING THE TABLE MOUNTING BRACKET

Decide on the location you wish to mount the stock feeder on your machine. Refer to Figs. 16, 17, and 18 for assistance when mounting the stock feeder assembly to a table saw, jointer, or shaper. To mount the stock feeder assembly to a machine table:

1. Position the mounting bracket (A) Fig. 2 at your desired location.
2. Mark the location where four mounting holes, three of which are shown at (B) Fig. 2 are to be drilled.
3. Center punch and drill four 3/8" diameter holes at the locations marked in **STEP 2**.

NOTE: Do not drill through any table ribs or table supports.

4. Fasten the mounting bracket (A) Fig. 2 to the table with a 2" bolt with a flat washer through each hole. Secure the bolts from underneath with a flat washer, a lockwasher, and a hex nut.

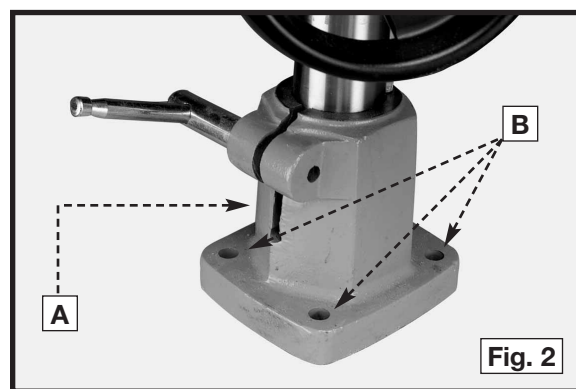

ASSEMBLING THE STOCK FEEDER

1. Loosen the locking handle (C) Fig. 3 and insert the vertical arm (D) of support assembly into the mounting bracket (A).
2. Tighten the locking lever (C) Fig. 3.
3. Loosen the locking handle (E) Fig. 3, and slide the horizontal arm (F) into the casting (G). Make certain that the gear rack (H) is inserted into slot on bottom of casting (G) and that the gear rack (H) engages with the gear located inside casting (G).

IMPORTANT: Insert the end of horizontal arm (F) Fig. 3 (the end that has the gear rack (H) extending all the way to the end of the arm) into the casting (G).

4. Insert a 3-1/2" screw (K) Fig. 3 into the handle (L). Thread the jam nut (M) on the end of the screw. Thread the handle (L) into handwheel (N).

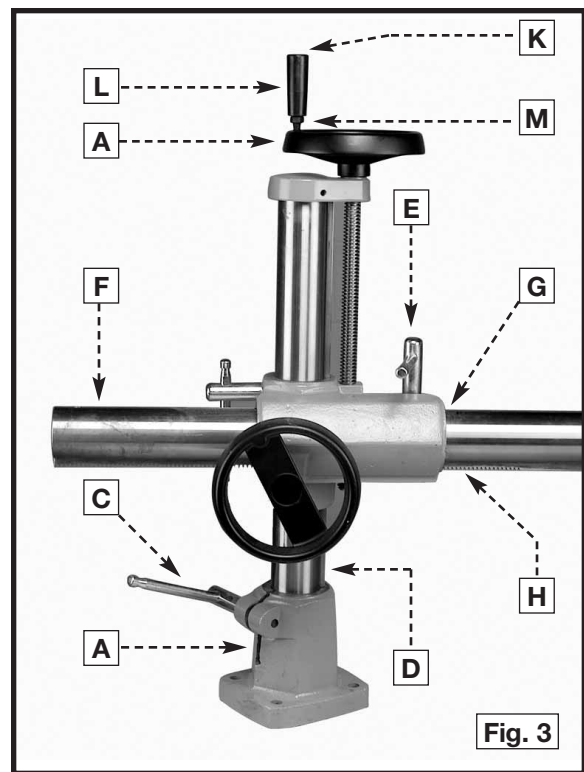

5. Loosen the two screws (not shown), located underneath the bracket (P) Fig. 4, and position the end bracket (P) over the end of the horizontal support arm (F). Tighten the two screws located underneath bracket (P).
6. Attach the angle joint (R) Fig. 4 on the feeder (S) and tighten the locking lever (T).
7. Install the feeder (S) Fig. 4 with angle joint (R) on the end bracket (P). Tighten the locking lever (V).

NOTE: You can make adjustments to the feeder operating positions later.

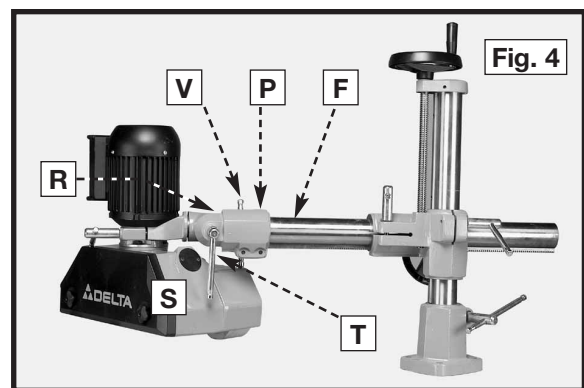

OPERATION

OPERATIONAL CONTROLS AND ADJUSTMENTS

MOTOR CONTROL SWITCH

The feeders come with a two-speed reversing motor.

1. To operate the feeder at low speed, rotate the switch (A) Fig. 5 to the "turtle" position (B).
2. To operate the feeder at high speed, rotate the switch (A) Fig. 5 to the "rabbit" position (C).
3. To operate the feeder in the opposite direction, rotate the switch (A) Fig. 5 counter-clockwise to either the "turtle" position (D) or "rabbit" position (E).
4. To turn the feed motor "OFF", rotate the switch (A) Fig. 5 to the "O" position.

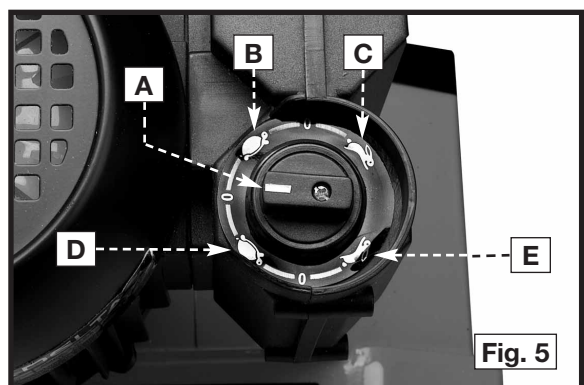

FEED RATE ADJUSTMENTS

(For 36-851 single phase and 36-852 three phase models ONLY!)

These stock feeders utilize feed rates of 13, 26, 36 and 72 feet per minute or 4, 8, 11 and 22 meters per minute. You can find the gear arrangement and feed rate chart attached to the inside cover (A) Fig. 6 of gear box. To remove the gear box cover (A) Fig. 6, turn the two knobs (B) counter-clockwise and remove the cover (A). The numbers shown in the circles on the chart (Fig. 7) indicate the number of teeth on the gears (C) and (D). With the 25 and 40 tooth gears in the arrangement shown at (C) Fig. 7, the feed rate is 13 FT/MIN (4 M/MIN) in low speed, and 26 FT/MIN (8 M/MIN) in high speed. By interchanging the position of the 25 and 40 tooth gears (D) Fig. 7, the feed rate is 36 FT/MIN (11 M/MIN) in low speed, and 72 FT/MIN (22 M/MIN) in high speed.

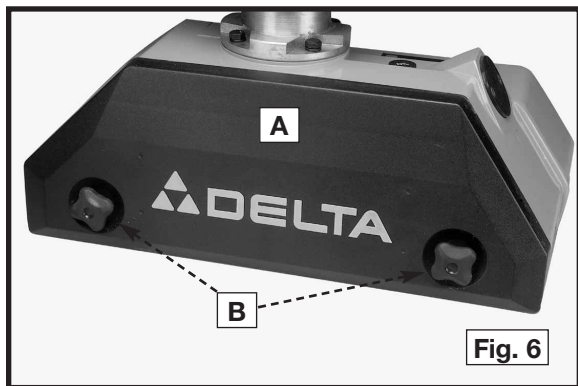

4-SPEED 3-ROLLER STOCK FEEDER				
C	GEAR ARRANGEMENT	MOTOR SWITCH	FEED RATE	
			FT/MIN	M/MIN
C	25 → 40	Turtle	13	4
	40 → 25	Rabbit	26	8
D	40 → 25	Turtle	36	11
	25 → 40	Rabbit	72	22

When you rotate the motor control switch (A) Fig. 8 to the "turtle" (B), the range of feed rate is 13 and 36 FT/MIN (4 and 11 M/MIN), depending on the gear arrangement as shown on chart (Fig. 7).

When you rotate the motor control switch (A) Fig. 8 to the "rabbit" (C), the range of feed rate is 26 and 72 FT/MIN (8 and 22 M/MIN), depending on the gear arrangement as shown on chart (Fig. 7).

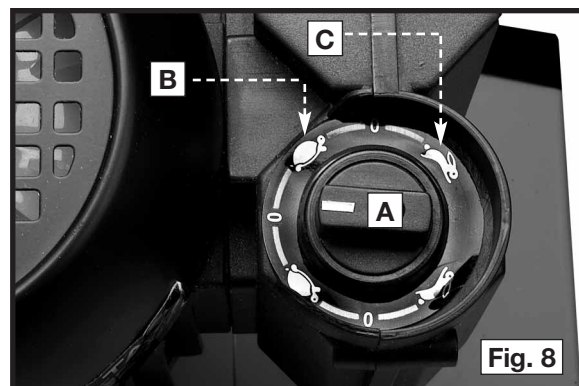

FEED RATE ADJUSTMENTS

(For 36-855 single phase and 36-856 three phase models ONLY!)

These stock feeders utilize feed rates of 6.5, 13, 18, 22, 36, 43, 55 and 108 feet per minute, or 2, 4, 5.5, 6.7, 11, 13, 16.5 and 33 meters per minute.

You can find the gear arrangement and feed rate chart attached to the inside cover (A) Fig. 9 of the gear box.

To remove the gear box cover (A) Fig. 9, turn the two knobs (B) counter-clockwise and remove the cover. The numbers shown in the circles on the chart Fig. 10 indicate the number of teeth on the gears (C) and (D).

With the 40 and 25 tooth gears in the arrangement shown at (C) Fig. 10, the feed/speed rates are 6.5, 13, 22 and 43 FT/MIN (2, 4, 6.7 and 13 M/MIN), depending on the motor and gear speeds.

By interchanging the position of the 40 and 25 tooth gears, (D) Fig. 10, the feed/speed rates are 18, 36, 55 and 108 FT/MIN (5.5, 11, 16.5 and 33 M/MIN), depending on the motor and gear speeds.

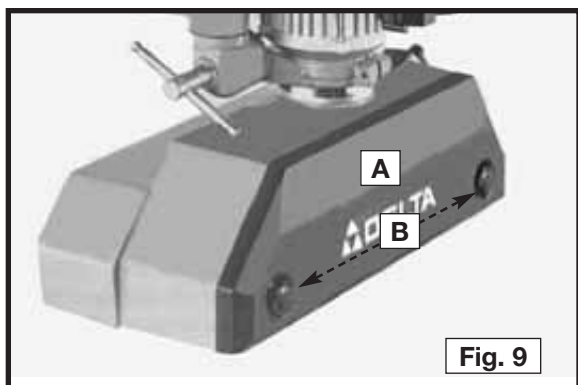

8-SPEED 4-ROLLER STOCK FEEDER					
C	GEAR ARRANGEMENT	MOTOR SWITCH	GEAR LEVER	FEED RATE	
				FT/MIN	M/MIN
C	40 → 25	Turtle	Turtle	6.5	2
	25 → 40	Rabbit	Rabbit	13	4
	40 → 25	Turtle	Rabbit	22	6.7
	25 → 40	Rabbit	Turtle	43	13
D	40 → 25	Turtle	Turtle	18	5.5
	25 → 40	Rabbit	Rabbit	36	11
	40 → 25	Turtle	Rabbit	55	16.5
	25 → 40	Rabbit	Turtle	108	33

The stock feeders use a two speed reversing motor (B) Fig. 11 to provide high and low speed/feed rates and to reverse the direction of feed.

When you rotate the motor control switch (A) Fig. 11 to the "turtle" (C), the feed rates are 6.5, 18, 22 and 55 FT/MIN (2, 5.5, 6.7 and 16.5 M/MIN), depending on the gear arrangement and gear lever position

When you rotate the motor control switch (H) Fig. 12 to the "rabbit" (D), the feed rates are 13, 36, 43 and 108 FT/MIN (4, 11, 13 and 33 M/MIN), depending on the gear arrangement and gear speed selection.

The 36-855 and 36-856 stock feeder models feature two position gear speed selection that enables the feeder to provide four additional speed/feed rates, and is activated by rotating the selection lever (A) Fig. 12.

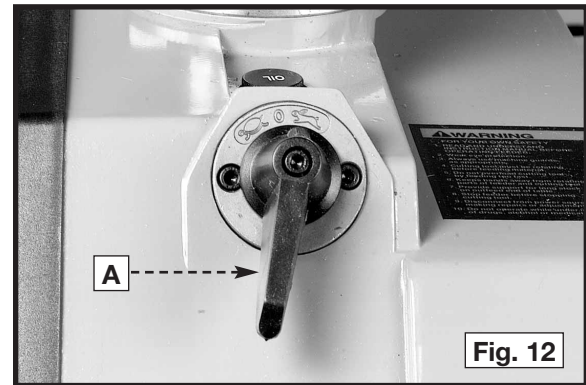
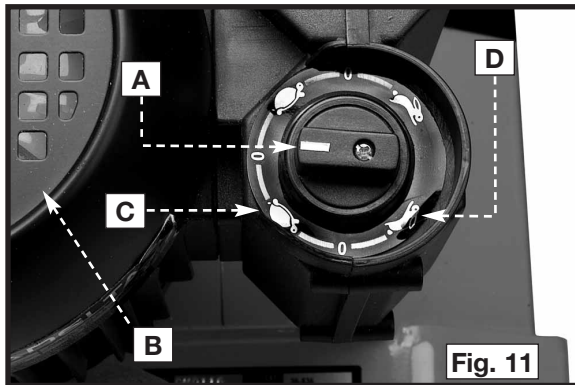

GEAR SPEED CONTROL LEVER

IMPORTANT: The gear speed lever (A) Fig. 13 **will not operate** unless the motor control switch (B) is in one of the forward or reverse positions. To operate the gear speed lever:

1. Rotate the motor control switch (B) Fig. 13 to the desired feed/speed position on the dial.
2. Rotate the lever (A) Fig. 13 counter-clockwise to the "turtle" position to obtain feed/speed rates of 6.5, 13, 18 or 36 FT/MIN (2, 4, 5.5 or 11 M/MIN), depending on the motor speed and gear arrangement.
3. Rotate the lever (A) Fig. 13 clockwise to the "rabbit" position to obtain feed/speed rates of 22, 43, 55 or 108 FT/MIN (6.7, 13, 16.5 or 33 M/MIN), depending on motor speed and gear arrangement.

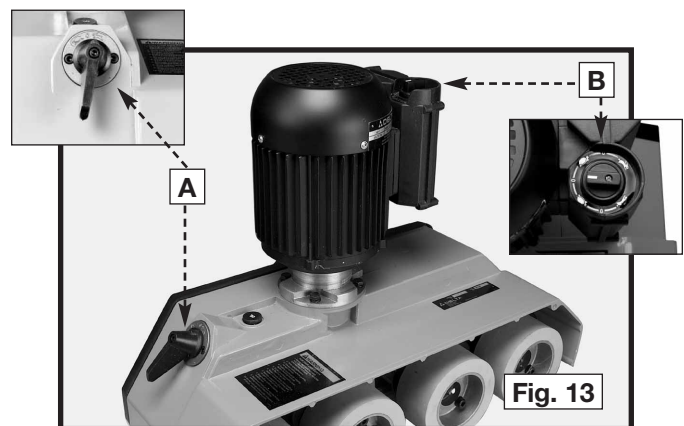

CHANGING GEAR ARRANGEMENT (FOR ALL MODELS)

⚠ WARNING DISCONNECT MACHINE FROM THE POWER SOURCE!

To interchange the arrangement of the gears inside the gear housing:

1. Remove the two locking knobs that attach the side cover to the gear housing and remove the side cover.
2. Remove the hex nuts (C) Fig. 14. Remove the gears (A) and (B).

NOTE: Always remove the lower gear first.

3. Switch the gears (A) and (B) Fig. 14 on the gear shafts and fasten with the hex nuts (C).

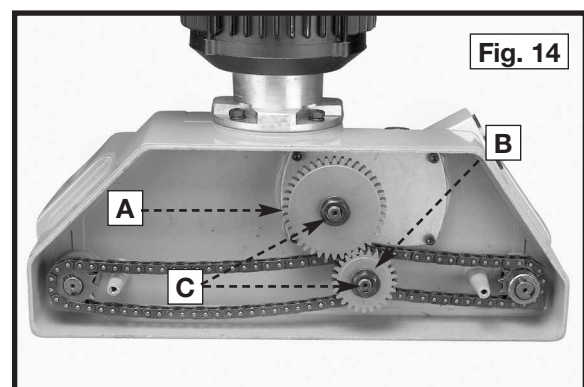

ADJUSTING OPERATING POSITIONS

⚠ WARNING DISCONNECT MACHINE FROM THE POWER SOURCE!

1. You can rotate the entire feeder assembly (A) Fig. 15 360 degrees in the mounting bracket (B) by loosening the locking lever (C).
2. To raise or lower the feeder assembly (A) Fig. 15, loosen the locking lever (D) and rotate the hand-wheel (E).
3. To move the feeder assembly (A) Fig. 15 in or out, loosen the locking lever (F) and rotate the hand-wheel (G).
4. To adjust the horizontal or angular position of feeder (K) Fig. 15, loosen the locking levers (H) and/or (J).
5. Tighten all locking levers after adjustments are completed.

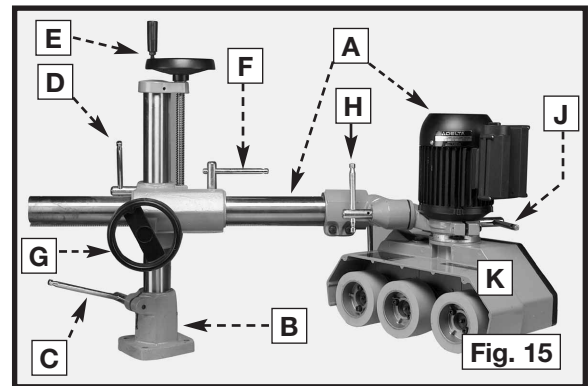

MACHINE USE

USING THE STOCK FEEDER ON A TABLE SAW

Position the feeder assembly (A) Fig. 16 so that the saw blade is placed between the middle roller (B) and the infeed roller (E). Also, position the stock feeder slightly at an angle to the direction of feed. For example, the outfeed roller (C) should be approximately 1/4" closer to the fence (D) than the infeed roller (E) (Fig. 16). This position will keep the workpiece against the fence.

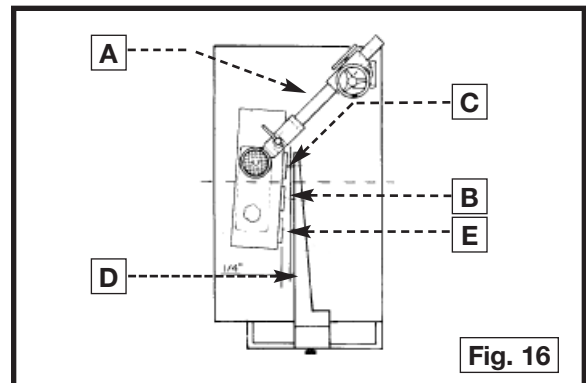

USING THE STOCK FEEDER ON A JOINTER

Position the feeder assembly (A) Fig. 17 so that all rollers (B), (C), and (D) are over the outfeed table (E) Fig. 17. Place the first roller (D) approximately 1/4" from the leading edge (F) of the outfeed table and the third roller (B) approximately 1/4" closer to the fence (G) than roller (D). The downward pressure of the rollers on the stock should be as light as possible while still maintaining proper feeding action.

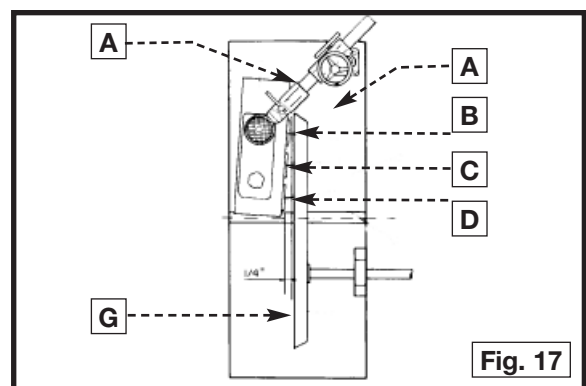

USING THE STOCK FEEDER ON A SHAPER

Position the feeder assembly (A) Fig. 18 so that the shaper cutter is between the middle roller (B) and infeed roller (C). The outfeed roller (D) should be approximately 1/4" closer to the outfeed fence (E) than the infeed roller (C).

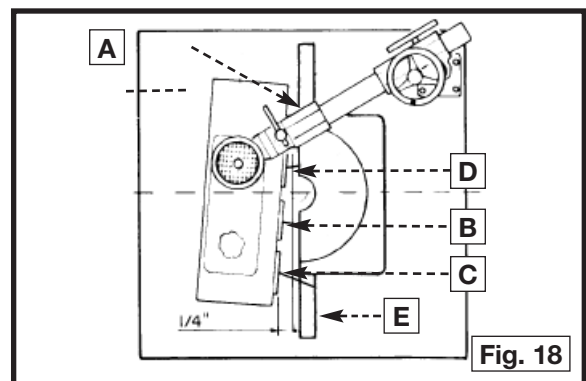

TROUBLESHOOTING

For assistance with your machine, visit our website at www.deltamachinery.com for a list of service centers or call the DELTA Machinery help line at 1-800-223-7278 (In Canada call 1-800-463-3582).

MAINTENANCE

FEED ROLLER REPLACEMENT

⚠ WARNING DISCONNECT MACHINE FROM THE POWER SOURCE!

You can remove each feed roller (A) Fig. 19 for replacement by removing four screws (B).

NOTE: The two long screws attach the rollers to the machine. The two short screws attach the two hub-halves together. Separate the two hub-halves, remove the roller, and install the new parts. Use the two short screws to tighten the hub-halves together. Replace the roller assembly on the machine and use the two long screws to secure it.

LUBRICATION

⚠ WARNING DISCONNECT MACHINE FROM THE POWER SOURCE!

You should lubricate the feed rollers (A) Fig. 19 approximately every 200 hours of use with grease through grease fittings (C) using grease gun supplied with the machine.

Coat the gear chains periodically with light machine oil. Change the gear oil approximately every 1000 hours of service or after heavy extended use using #90 weight gear oil.

To gain access to the gear oil chamber, turn the oil cap (D) Fig. 19 counter-clockwise. Keep the oil level between 2 to 2-1/4" below the top of the gear case (E).

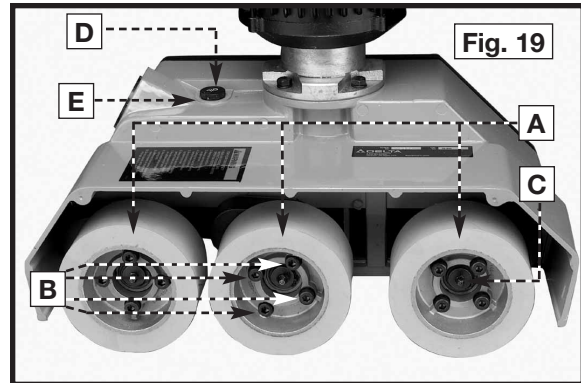

KEEP MACHINE CLEAN

Periodically blow out all air passages with dry compressed air. All plastic parts should be cleaned with a soft damp cloth. NEVER use solvents to clean plastic parts. They could possibly dissolve or otherwise damage the material.

⚠ WARNING Wear ANSI Z87.1 safety glasses while using compressed air.

FAILURE TO START

Should your machine fail to start, check to make sure the prongs on the cord plug are making good contact in the outlet. Also, check for blown fuses or open circuit breakers in the line.

LUBRICATION

Apply household floor paste wax to the machine table and extension table or other work surface weekly.

PROTECTING CAST IRON FROM RUST

To clean and protect cast iron tables from rust, you will need the following materials: 1 pushblock from a jointer, 1 sheet of medium Scotch-Brite™ Blending Hand Pad, 1 can of WD-40®, 1 can of degreaser, 1 can of TopCote® Aerosol. Apply the WD-40 and polish the table surface with the Scotch-Brite pad using the pushblock as a holddown. Degrease the table, then apply the TopCote® accordingly.

SERVICE



PARTS, SERVICE OR WARRANTY ASSISTANCE

All Delta Machines and accessories are manufactured to high quality standards and are serviced by a network of Porter-Cable • Delta Factory Service Centers and Delta Authorized Service Stations. To obtain additional information regarding your Delta quality product or to obtain parts, service, warranty assistance, or the location of the nearest service outlet, please call 1-800-223-7278 (In Canada call 1-800-463-3582).

ACCESSORIES

A complete line of accessories is available from your Delta Supplier, Porter-Cable • Delta Factory Service Centers, and Delta Authorized Service Stations. Please visit our Web Site www.deltamachinery.com for a catalog or for the name of your nearest supplier.

⚠ WARNING Since accessories other than those offered by Delta have not been tested with this product, use of such accessories could be hazardous. For safest operation, only Delta recommended accessories should be used with this product.

WARRANTY



Two Year Limited New Product Warranty

Delta will repair or replace, at its expense and at its option, any new Delta machine, machine part, or machine accessory which in normal use has proven to be defective in workmanship or material, provided that the customer returns the product prepaid to a Delta factory service center or authorized service station with proof of purchase of the product within two years and provides Delta with reasonable opportunity to verify the alleged defect by inspection. For all refurbished Delta product, the warranty period is 180 days. Delta may require that electric motors be returned prepaid to a motor manufacturer's authorized station for inspection and repair or replacement. Delta will not be responsible for any asserted defect which has resulted from normal wear, misuse, abuse or repair or alteration made or specifically authorized by anyone other than an authorized Delta service facility or representative. Under no circumstances will Delta be liable for incidental or consequential damages resulting from defective products. This warranty is Delta's sole warranty and sets forth the customer's exclusive remedy, with respect to defective products; all other warranties, express or implied, whether of merchantability, fitness for purpose, or otherwise, are expressly disclaimed by Delta.

NOTES

PORTER-CABLE • DELTA SERVICE CENTERS (CENTROS DE SERVICIO DE PORTER-CABLE • DELTA)

Parts and Repair Service for Porter-Cable • Delta Machinery are Available at These Locations
(Obtenga Refaccion de Partes o Servicio para su Herramienta en los Sigüientes Centros de Porter-Cable • Delta)

ARIZONA

Phoenix 85013-2906
4501 N. 7th Ave.
Phone: (602) 279-6414
Fax: (602) 279-5470

CALIFORNIA

Ontario 91761 (Los Angeles)
3949A East Guasti Road
Phone: (909) 390-5555
Fax: (909) 390-5554

San Diego 92111
7290 Clairemont Mesa Blvd.
Phone: (858) 279-2011
Fax: (858) 279-0362

San Leandro 94577 (Oakland)
3039 Teagarden Street
Phone: (510) 357-9762
Fax: (510) 357-7939

COLORADO

Denver 80223
700 West Mississippi Ave.
Phone: (303) 922-8325
Fax: (303) 922-0245

FLORIDA

Davie 33314 (Miami)
4343 South State Rd. 7 (441)
Unit #107
Phone: (954) 321-6635
Fax: (954) 321-6638

Tampa 33634
4909 West Waters Ave.
Phone: (813) 884-0434
Fax: (813) 888-5997

GEORGIA

Forest Park 30297 (Atlanta)
5442 Frontage Road,
Suite 112
Phone: (404) 608-0006
Fax: (404) 608-1123

ILLINOIS

Addison 60101 (Chicago)
400 South Rohlwing Rd.
Phone: (630) 424-8805
Fax: (630) 424-8895

Woodridge 60517 (Chicago)
2033 West 75th Street
Phone: (630) 910-9200
Fax: (630) 910-0360

KANSAS

Overland Park 66214
9201 Quivira Road
Phone: (913) 495-4330
Fax: (913) 495-4378

MARYLAND

Elkridge 21075 (Baltimore)
7397-102 Washington Blvd.
Phone: (410) 799-9394
Fax: (410) 799-9398

MASSACHUSETTS

Franklin 02038 (Boston)
Franklin Industrial Park
101E Constitution Blvd.
Phone: (508) 520-8802
Fax: (508) 528-8089

MICHIGAN

Madison Heights 48071 (Detroit)
30475 Stephenson Highway
Phone: (248) 597-5000
Fax: (248) 597-5004

MINNESOTA

Eden Prairie 55344
9709 Valley View Road
Phone: (952) 884-9191
Fax: (952) 884-3750

MISSOURI

St. Louis 63146
11477 Page Service Drive
Phone: (314) 997-9100
Fax: (314) 997-9183

NEW YORK

Flushing 11365-1595 (N.Y.C.)
175-25 Horace Harding Expwy.
Phone: (718) 225-2040
Fax: (718) 423-9619

NORTH CAROLINA

Charlotte 28270
9129 Monroe Road, Suite 115
Phone: (704) 841-1176
Fax: (704) 708-4625

OHIO

Columbus 43229
1948 Schrock Road
Phone: (614) 895-3112
Fax: (614) 895-3187

Cleveland 44125
8001 Sweet Valley Drive Unit #19
Phone: (216) 447-9030
Fax: (216) 447-3097

OREGON

Portland 97230
14811 North East Airport Way
Phone: (503) 255-6556
Fax: (503) 255-6543

PENNSYLVANIA

Willow Grove 19090
(Philadelphia)
520 North York Road
Phone: (215) 658-1430
Fax: (215) 658-1433

TEXAS

Carrollton 75006 (Dallas)
1300 Interstate 35 N, Suite 112
Phone: (972) 446-2996
Fax: (972) 446-8157

Houston 77022-2122

536 East Tidwell Rd.
Phone: (713) 692-7111
Fax: (713) 692-1107

WASHINGTON

Auburn 98001(Seattle)
3320 West Valley HWY, North
Building D, Suite 111
Phone: (253) 333-8353
Fax: (253) 333-9613

Authorized Service Stations are located in many large cities. Telephone **800-438-2486** or **731-541-6042** for assistance locating one. Parts and accessories for Porter-Cable-Delta products should be obtained by contacting any Porter-Cable-Delta Distributor, Authorized Service Center, or Porter-Cable-Delta Factory Service Center. If you do not have access to any of these, call **800-223-7278** and you will be directed to the nearest Porter-Cable-Delta Factory Service Center. Las Estaciones de Servicio Autorizadas están ubicadas en muchas grandes ciudades. Llame al **800-438-2486** ó al **731-541-6042** para obtener asistencia a fin de localizar una. Las piezas y los accesorios para los productos Porter-Cable-Delta deben obtenerse poniéndose en contacto con cualquier distribuidor Porter-Cable-Delta, Centro de Servicio Autorizado o Centro de Servicio de Fábrica Porter-Cable-Delta. Si no tiene acceso a ninguna de estas opciones, llame al **800-223-7278** y le dirigirán al Centro de Servicio de Fábrica Porter-Cable-Delta más cercano.

CANADIAN PORTER-CABLE • DELTA SERVICE CENTERS

ALBERTA

Bay 6, 2520-23rd St. N.E.
Calgary, Alberta
T2E 8L2
Phone: (403) 735-6166
Fax: (403) 735-6144

BRITISH COLUMBIA

8520 Baxter Place
Burnaby, B.C.
V5A 4T8
Phone: (604) 420-0102
Fax: (604) 420-3522

MANITOBA

1699 Dublin Avenue
Winnipeg, Manitoba
R3H 0H2
Phone: (204) 633-9259
Fax: (204) 632-1976

ONTARIO

505 Southgate Drive
Guelph, Ontario
N1H 6M7
Phone: (519) 767-4132
Fax: (519) 767-4131

QUÉBEC

1515 ave.
St-Jean Baptiste, Suite 160
Québec, Québec
G2E 5E2
Phone: (418) 877-7112
Fax: (418) 877-7123

1447, Begin
St-Laurent, (Montréal),
Québec
H4R 1V8
Phone: (514) 336-8772
Fax: (514) 336-3505

The following are trademarks of PORTER-CABLE • DELTA (Las siguientes son marcas registradas de PORTER-CABLE • DELTA S.A.) (Les marques suivantes sont des marques de fabricant de la PORTER-CABLE • DELTA): Auto-Set®, BAMMER®, B.O.S.S.®, Builder's Saw®, Contractor's Saw®, Contractor's Saw II™, Delta®, DELTACRAFT®, DELTAGRAM™, Delta Series 2000™, DURATRONIC™, Emc2™, FLEX®, Flying Chips™, FRAME SAW®, Grip Vac™, Homecraft®, INNOVATION THAT WORKS®, Jet-Lock®, JETSTREAM®, 'kickstand', LASERLOC®, MICRO-SET®, Micro-Set®, MIDI LATHE®, MORTEN™, NETWORK™, OMNIJIG®, POCKET CUTTER®, PORTA-BAND®, PORTA-PLANE®, PORTER-CABLE®(design), PORTER-CABLE®PROFES-SIONAL POWER TOOLS, PORTER-CABLE REDEFINING PERFORMANCE™, Posi-Matic®, Q-3®(design), QUICKSAND®(design), QUICKSET™, QUICKSET II®, QUICKSET PLUS™, RIPTIDE™(design), SAFE GUARD II®, SAFE-LOC®, Sanding Center®, SANDTRAP®(design), SAW BOSS®, Sawbuck™, Sidekick®, SPEED-BLOC®, SPEEDMATIC®, SPEEDTRONIC®, STAIR EASE®, The American Woodshop®(design), The Lumber Company®(design), THE PROFESSIONAL EDGE®, THE PROFESSIONAL SELECT®, THIN-LINE™, TIGER®, TIGER CUB®, TIGER SAW®, TORQ-BUSTER®, TORQ-BUSTER®, TRU-MATCH™, TWIN-LITE®, UNIGUARD®, Unifence®, UNIFEEDER™, Unihead®, Uniplane™, Unirip®, Unisaw®, Univise®, Versa-Feeder®, VERSA-PLANE®, WHISPER SERIES®, WOODWORKER'S CHOICE™.

Trademarks noted with ™ and ® are registered in the United States Patent and Trademark Office and may also be registered in other countries. Las Marcas Registradas con el signo de ™ y ® son registradas por la Oficina de Registros y Patentes de los Estados Unidos y también pueden estar registradas en otros países.